

vicon máquinas agrícolas ltda
pendulum - action spreader
Instruction Manual, Parts Catalog
and Calibration Charts

English

PS 203	PS 303	PS 403S	PS 503S	PS 603S
PS 753	PS 953	PS 1153	PS 1353	PS 1553T

abonadora pendular
*Manual de Instrucciones, Catálogo de
Piezas y Tablas de Calibración*

Español

PS 203	PS 303	PS 403S	PS 503S	PS 603S
PS 753	PS 953	PS 1153	PS 1353	PS 1553T



1. Safety Instructions.



Before handling equipment, it is necessary to check if the operator responsible has been instructed on the correct way to operate the machine. For this, careful reading of the Instruction Manual is advised, thus guaranteeing that the machine will be operated in the best way possible, avoiding accidents and premature damage to the equipment.

- A. Do not use the equipment for purposes for which it was not designed, avoiding the risk of accidents.
- B. Wash the machine after use, in order to guarantee longer durability.
- C. Never leave the fertilizer running. If you need to leave, lower the machine to the ground, turn off the engine, engage the parking break and remove the key from the contact point.
- D. Always adapt the tractor's speed to the location's conditions. Avoid sudden maneuvers.
- E. If necessary, use appropriate ballasts.
- F. Do not transport people on the equipment, nor on the tractor, if there is no space to do so.
- G. When working below the fertilizer suspended by a hydraulic lift, do not forget to place secure supports.
- H. Check for the presence of children, animals or other people, warning them to keep their distance from the equipment when operating.
- I. Always carry out regulation or lubrication when the machine is disconnected from the tractor's power outlet.
- J. If there are any mechanical damages present, turn off the equipment and fix the damage before turning on the machine again.
- K. Avoid the use of loose or baggy clothing, since they can get stuck in the equipment's movable parts and may cause accidents.
- L. Check that the locking pins are in place and check the tightness of the screws.
- M. The fertilizer's power outlet must be turned off when turning the tractor's engine either on or off.
- N. Do not work with the machine without protection from the movable parts (drive shaft, gear box and protective disc cover).
- O. If checking or changing the blades' settings, turn off the power outlet and the engine and wait for the disc to completely stop turning.
- P. To prevent accidents and damages to the operator, there should be a certificate that confirms that he or she recognizes the safety standards and instructions for carrying out operations with the equipment, appropriately and safely.
- Q. The use of personal protection equipment (PPEs) is mandatory.

1. Instrucciones de Seguridad.



Antes de proceder con el manejo del equipo, verificar si el operador responsable está instruido en la operación correcta de la máquina. Por eso aconsejamos hacer una lectura atenta del manual de instrucciones para poder operar la máquina de la mejor forma posible, evitando accidentes y daños precoces en el equipo.

- A. Evite de hacer uso del equipo para otros fines que no fue proyectado, evitándose así el peligro de accidentes.*
- B. Después de su uso, lavar la máquina para dar más garantía de durabilidad.*
- C. Evite de dejar encendido la abonadora. Si desea salir, baje la máquina al suelo, apague el motor, accione el freno de parada y retire la llave de contacto.*
- D. Adaptar siempre la velocidad del tractor a las condiciones locales. Evite de hacer maniobras peligrosas.*
- E. Si es necesario, usar lastres apropiados.*
- F. Evite de transportar personas encima del equipo, ni en tractor, si en caso no hay espacio para este fin.*
- G. Si desea trabajar debajo de la abonadora, levantarlo con el gato hidráulico, no te olvides de poner apoyos de seguridad.*
- H. Tener cuidado con la presencia de niños, animales u otras personas, avisándolos para que se mantengan alejados del equipo.*
- I. Siempre haga la regulación o lubricación con la máquina apagada de la tomada de fuerza del tractor.*
- J. Si notas la presencia de cualquier daño mecánico, apague el equipo y pedir al mecánico para su reparo antes de encender de nuevo la máquina.*
- K. Evite de usar ropas muy sueltas u holgadas, porque estas pueden prenderse en las partes móviles del equipo y causar accidentes.*
- L. Cerciorase si los pines-traba están bien posicionados y verificar el aprieto de los tornillos.*
- M. Toma de corriente del fertilizante se debe apagar al encender el motor del tractor mismo encendido o apagado.*
- N. Evite de trabajar con la máquina sin protección de las partes móviles, (cardán, caja de transmisión y tapa protectora del disco).*
- O. En caso de verificación o cambio de regulación de las paletas, apagar la tomada de fuerza y el motor y aguardar que el disco deje de girar por completo.*
- P. Para prevenir accidentes y daños al operador debes cerciorarte de que el mismo, conoce las normas de seguridad y las instrucciones para realizar las operaciones con el equipo de forma adecuada y con seguridad.*
- Q. Es obligatorio el uso de los equipos de protección individual (EPI).*

Index	PAGE
1. Safety Instructions	1
2. Technical Data	3 - 4
3. General Information	4
4. Packing and Assembly	5
5. Connecting the Spreader to the Tractor	6
6. Connecting the PTO Shaft	7
7. How to Regulate the Spreader	8
8. How to Regulate for band Spreading	9
9. How to Distribute Spreading Evenly	10
Cleaning and Greasing	10
10. Pendulum-action unit with adjustment for distribution width	11 - 12
11. Calibration Charts. How to Regulate the Spreader	12
L.A.N. 26% Nitrogen	23 - 24
Potassium Nitrate Granules	24 - 26
NPK Coarse 12-10-18	26 - 27
NPK Fine 23-23-0	28 - 29
Superphosphate 19%	29 - 31
K.C.L. 60	31 - 32
Agricultural Lime with stirring device	32
Rye Grass Seed with stirring device	33
Wheat Seed	33
12. Parts and Spares Catalog - Series 22400:	
Spreader Unit	34
Spreader Unit	35
Spreader Unit	36
Chassis and Hopper: PS 203, PS 303	37
Chassis and Hopper: PS 403S, PS 503S, PS 603S	38
Chassis and Hopper: PS 753, PS 953, PS 1153, PS 1353, PS 1553T	39
Cable: PS 603S, PS 753/Trailer	40
Trailer: PS 1353T, PS 1553T	41

2. Technical Data.



Models	PS 203	PS 303	PS 403S	PS 503S
Capacity of hopper (liters)	200	300	400	500
Empty weight (kg)	89	100	109	115
Height (cm)	77	92	98	110
Width (cm)	90	103	145	145
EFFECTIVE spreading width	up to 14 meters			
PTO shaft rotation	540 RPM for all models			
Outflow adjustment	10 - 2000 kg/ha			
Tires	-	-	-	-

Equipment subject to changes without notice.

Data informed on the table may vary, according to humidity level, weight, type of material and

3. General Information.

The **Pendulum - Action Fertilizer Spreader** was developed to spread pelleted fertilizer, calcium, powders and seeds with absolute precision.

For the fertilization of line-crops such as coffee, citrus and other fruit trees, just change the standard Pendulum (07665) for the special Pendulum (70445) and fertilizer will spread in two definite bands close to the plants or trees.

The distance between bands varies with the length of the Pendulum. (See table ⑤ page 9).

The mechanical part of all Spreaders is the same, with changes only for the hopper capacity, which varies from 600 to 3,300 lb, depending on the users need and the tractor available on the property.

The working width varies from 19.7 to 46 feet, depending on the weight and type of material being spread.

The Pendulum Spreader ships with a standard stirring device (parts 21142 & 21406), which guarantees an even spreading pattern, regardless of dry, powdered or granulated material is being used.

If the material used is humid or moist, such as calcium, gypsum and hygroscopic fertilizers, a special stirring device is needed (parts 15445 & 36180).

For any questions or suggestions, please contact our Technical Support Department.

2. Technical Data.



PS 603S	PS 753	PS 953	PS 1153	PS 1353	PS 1553T
600	750	950	1150	1350	1550
120	151	160	170	185	360
129	98	110	120	127	179
145	180	180	180	180	180
up to 14 meters					
540 RPM for all models					
10 - 2000 kg/ha					
-	-	-	-	-	600 x 16 or 900 x 16

working conditions.

4. Packing and Assembly.

The Spreader is partially disassembled for transport, therefore the following parts will have to be assembled on site:

- The Pendulum unit.
- The Hopper and its three support plates for the tubular frame.
- The disc regulating handle.

The Pendulum

For assembly of the Pendulum you will need:

- Two fine-threaded screws with nuts and four washers.
- Aluminium flange (83262) to fix the Pendulum to the frame.

Assemble as follows:

1. Place flange ① over and around Spreader.
2. Insert screws and washers ② & ③.
3. Tighten both screws using the correct torque (i.e. 160 Nm/16 kgfm).

Correct torque maintenance is recommended in order to avoid damage to the Pendulum neck and coupling.

The Hopper

The Hopper ⑦ is fixed to the frame by three reinforced plates in such a way that the hopper may be removed easily for cleaning ④ & ⑥. (See page 10).

- Fix the three mounting plates to the frame, using the 16 screws ⑧, through the pre-drilled holes.
- The screws flat heads must be on the inside of the Hopper ⑤.
- For the PS 603S model, attach the 53 gallons extension ⑨ to the Hopper.

The Regulator Bar

To assemble the regulator bar you will need to:

- Fix the flow scale to the flat end of the handle.
- Slide the handle into the keyhole and lock it with the locking pin.

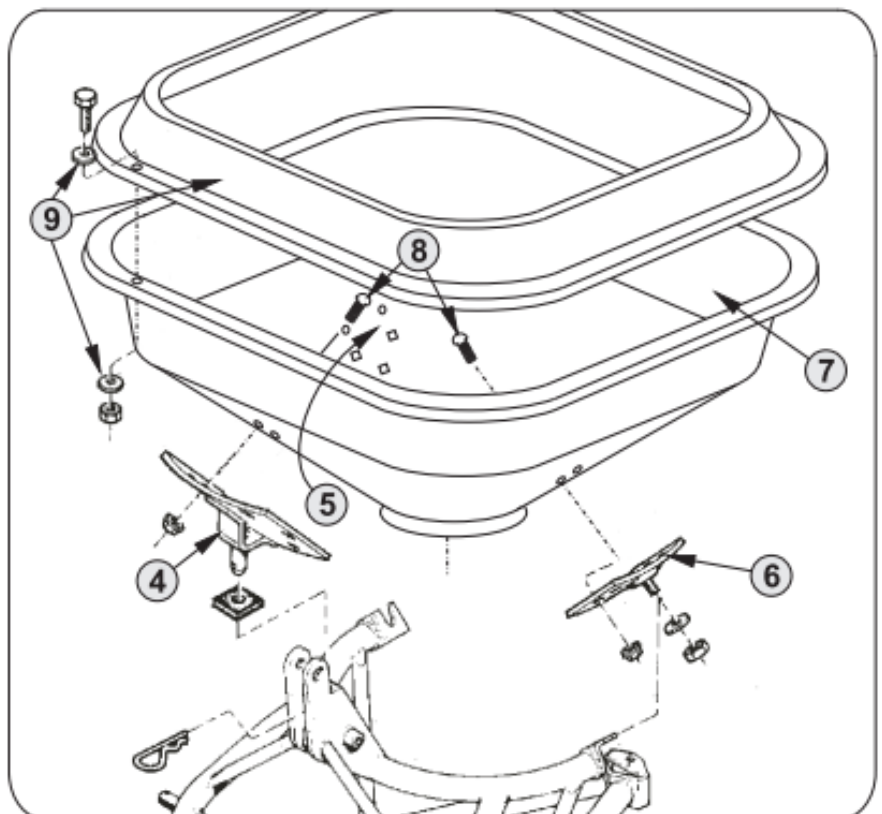
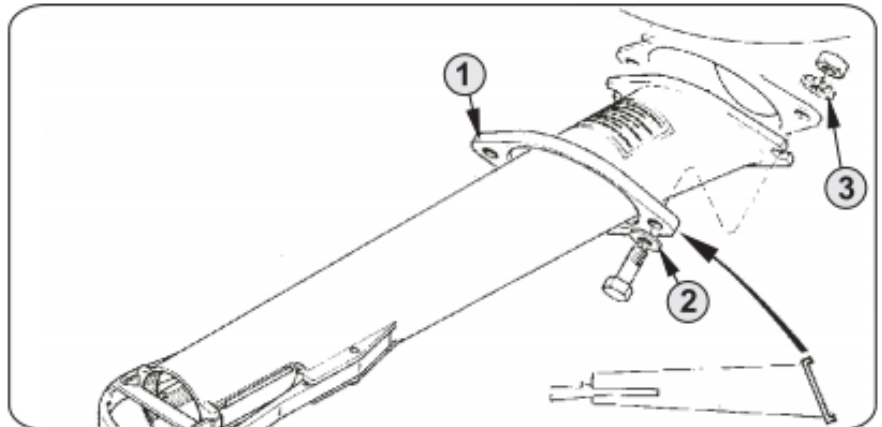

5. Connecting the Spreader to the Tractor.

Basically the Pendulum Spreader may be attached to any tractor equipped with a hydraulic lift.

It is important that the topline on the Spreader, mounted to the three - point link on the tractor, has a maximum gap of 2 inches in order to avoid contact of the two sidelinks ③ with the tractor tires. It is recommended stabilizer bars or chains to be used.

As an added safety measure, it is recommended to protect the tractor PTO with a cover plate or bus.

The linkage pins of the Spreader were designed for both categories I & II ① & ②.

From the front and from the side, it is important that the Spreader is in a horizontal position ④ and that the Pendulum is at 29.5 inches from the ground. ⑤

When used on a lightweight tractor, it is advisable to use front weights on the tractor.

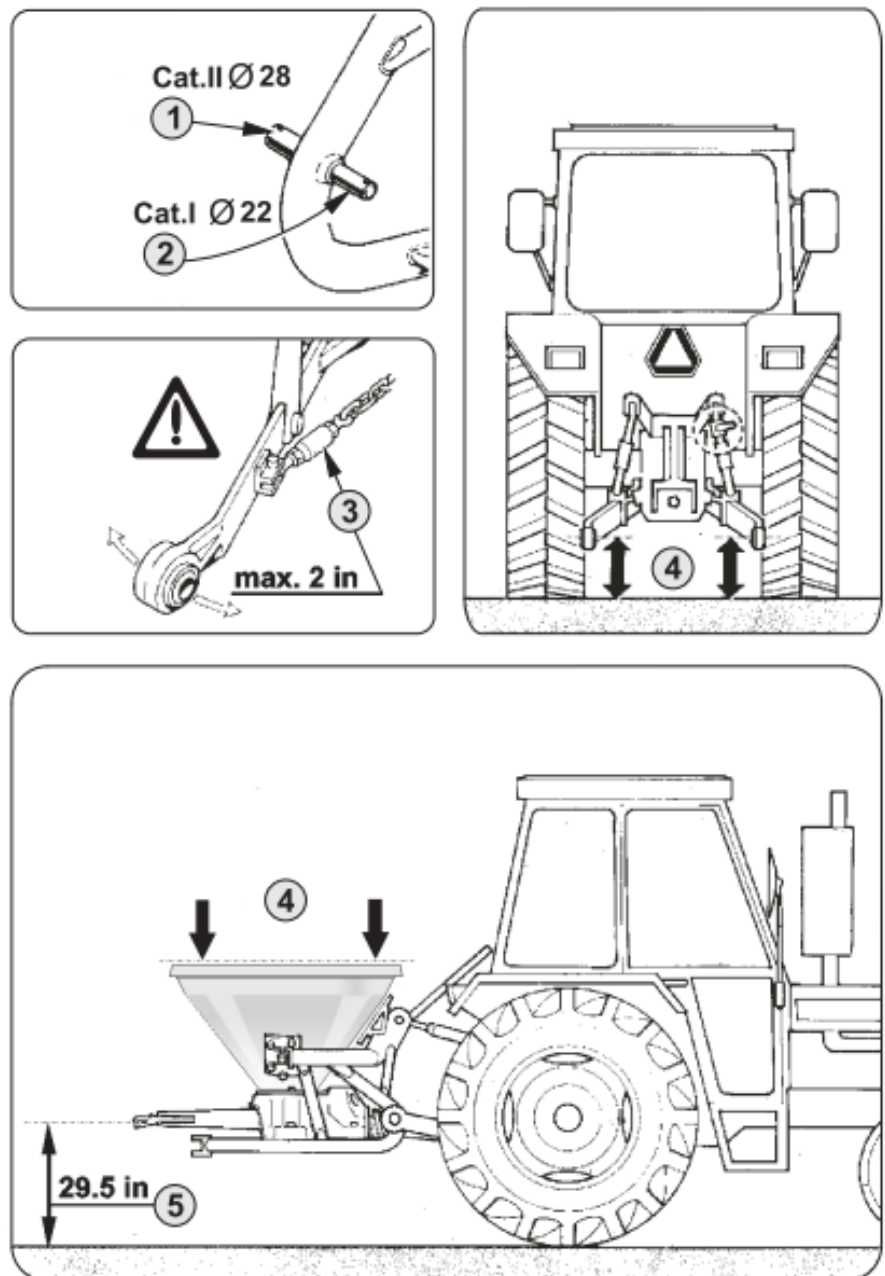

6. Connecting the PTO Shaft.

Lift the Spreader until the PTO shaft reaches the height of the shaft connection of the tractor (1).

Connect half of the PTO shaft to the tractor and the other half to the Spreader, holding them side by side (2).

Make sure that both tubes overlap each other by at least 1 inch (3).

If the shaft is too long, first cut the guard tubes to the correct length, and then cut the profile tubes to the correct length (4 & 5).

Remove burrs, clean well and regrease the inner profile tube on its outside.

NOTE: The angle of the moving PTO shaft must never exceed 30° (6).

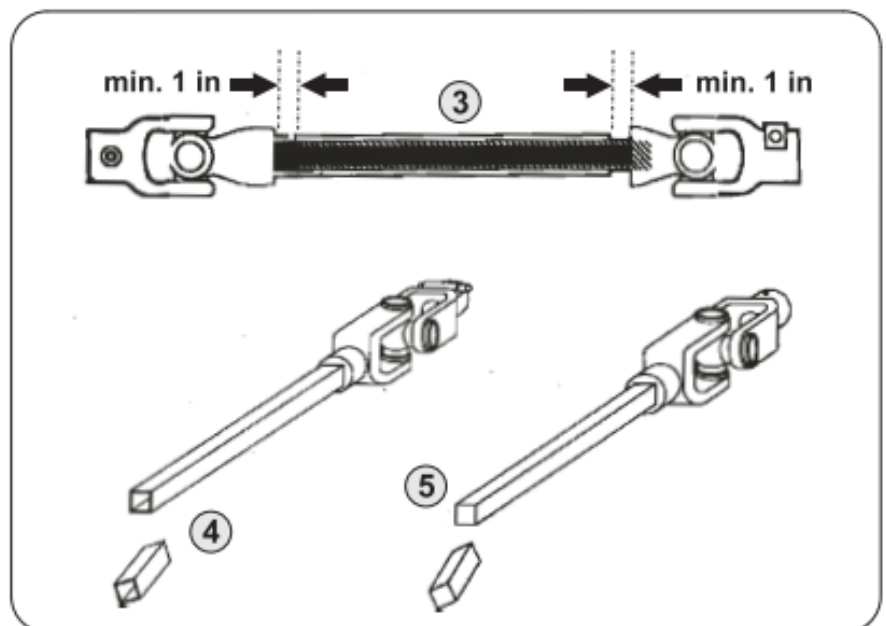
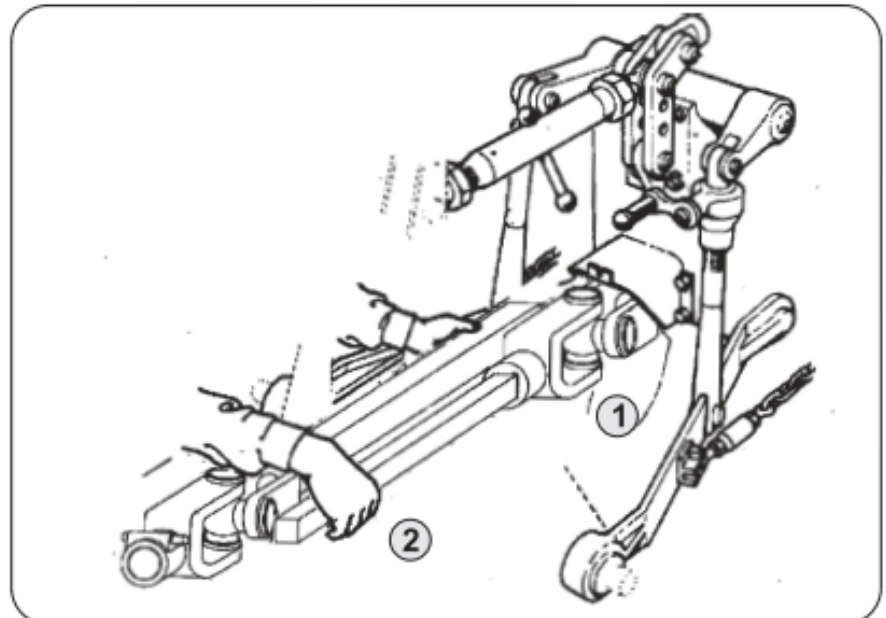
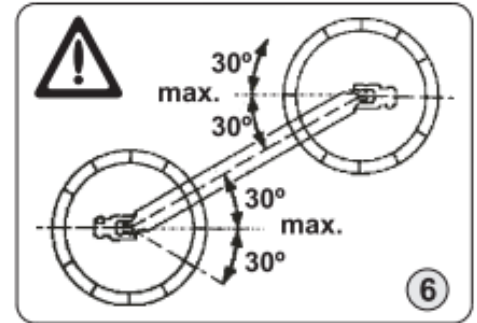

7. How to Regulate the Spreader.

With a working revolution of 540 rpm, the amount of material being spread depends on two factors: the opening of flow rate regulator, and the speed of the tractor.

Also for economic reasons it is very important that the right amount of product is being spread, in accordance to the type of culture and the soil's need. Prior to spreading, adjust the Spreader with accuracy. Following are detailed examples for the spreading of fertilizer at 130 lb/acre and how to distribute 0.11 lb per tree through bandspreading.

Example 1: Spreading 130 lb/acre

- A. $130 \text{ lb/acre} = 132 \text{ lb}/4.000\text{m}^2$
- B. If the tractor works at a speed of 3.72 mph = 3.72 miles in 60 minutes.
- C. We measure the width of the spreading pattern, e.g. 26 feet.
- D. Now we know that in one minute we can fertilize $26 \text{ feet} \times 0.062 \text{ mi} = 0.005 \text{ mi} \times 0.062 \text{ mi} = 0.031 \text{ mi}^2$ and $0.031 \text{ mi}^2 \times 0.033 \text{ lb} = 0.033 \text{ lb}$ (item A) should be released by the spreader, per minute (See also page 10).

With this result of 26,40 lb/min we can now regulate the Spreader as follows:

- Disconnect the Pendulum Spreader. ①
- Place a bucket underneath the opening. ②
- Close the regulator disc. ③
- Set the nylon adjuster to about the correct setting. ④
- Fill hopper with pellets and start and accelerate the PTO to 540 rpm. ⑤
- Open the regulator disc for one minute and weigh the amount of pellets collected. If the weight is under 26.40 lb, open the adjuster more. If the collected weight is in excess of 26,40 lb ⑥, close the adjuster until right amount is reached. Write down the right setting for future use.

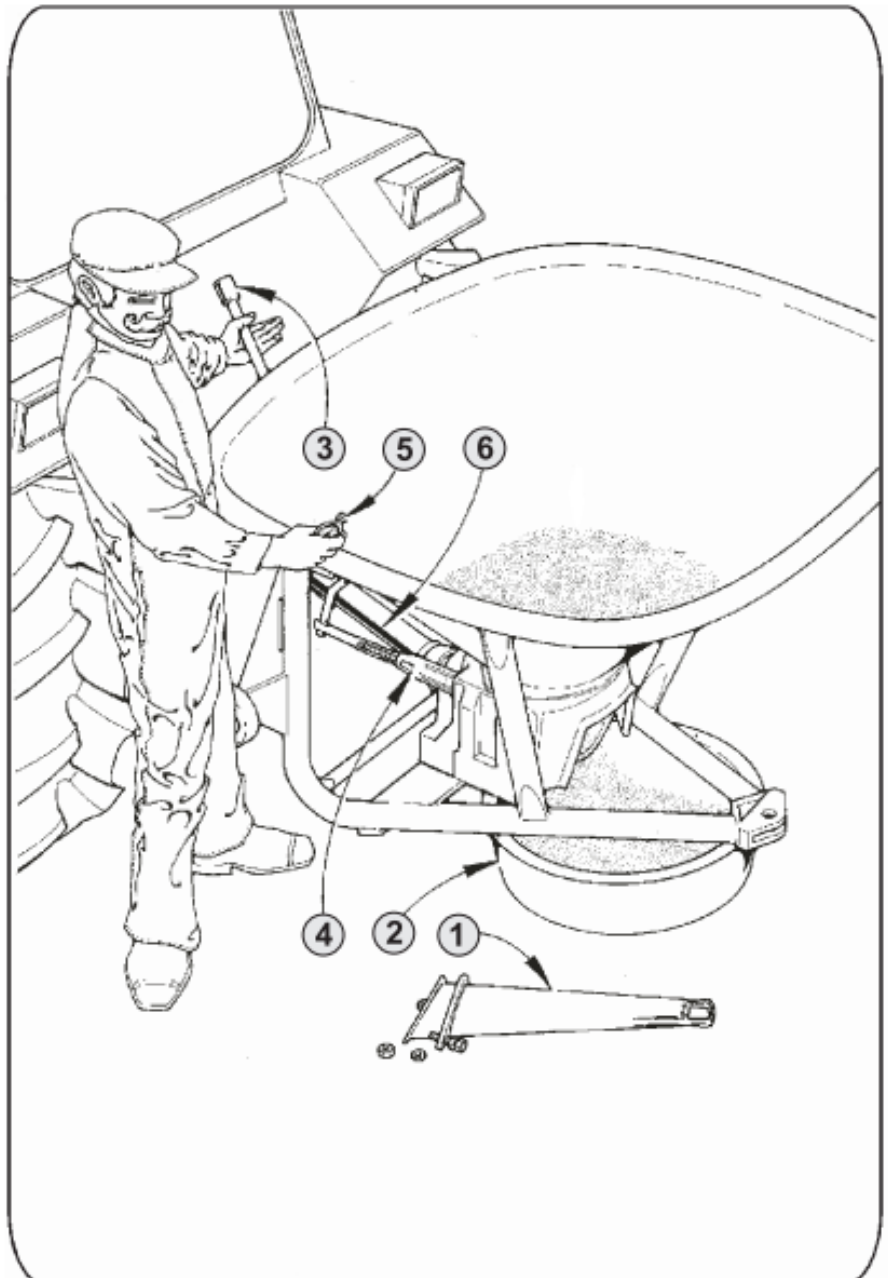

8. How to Regulate for band Spreading.

Example 2: Spreading 50 grams per tree:

- A. Assuming the culture is planted at 1,5 m intervals with a 4 meters width between rows. ①
- B. If the tractor moves at 6 kph - 6.000 m in 60 minutes = 100 meters per minute.
- C. Every 100 meters we will service 66 tree on either side = 132 trees total.
- D. With the objective of fertilizing each tree with 50 grams, we know that the flow rate will have to be $132 \times 50 = 6.600$ kg.
We can now regulate the Spreader as in the previous example.

In order to spread in two bands, we will have to change the Standard Pendulum (07665) for the Special Pendulum - (70445). Depending on the length of the Pendulum (70445), the maximum distance between rows will vary (see table ⑤).

In addition to the standard stirring device fixed permanently to the Spreader, we can supply an extra stirring device ② to be used with moist or humid fertilizer. ④

When mounting the stirring device, make sure there is no movement.

CAUTION: Never use the extra stirring device ② with granulated fertilizer ③ or seeds, as this will damage them.

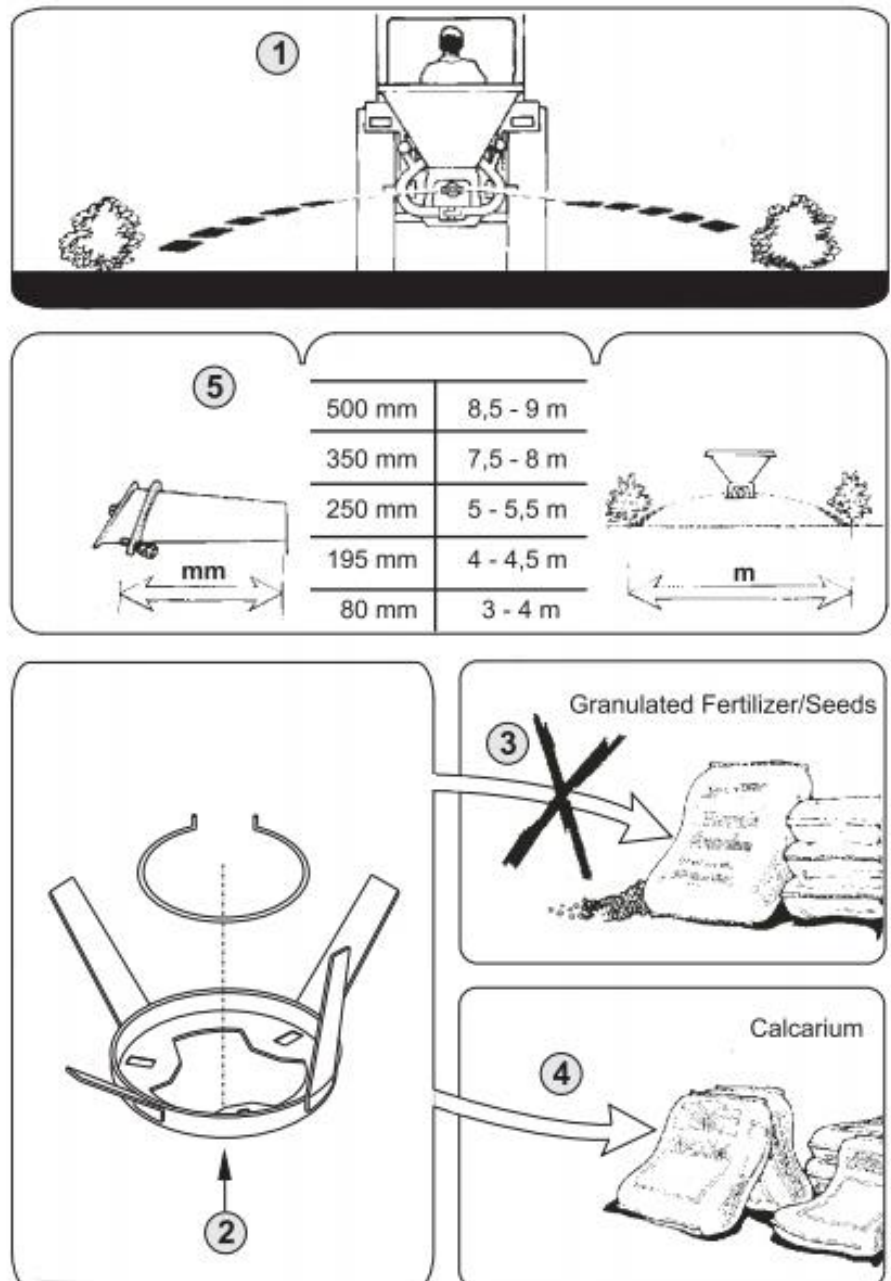

9. How to Distribute Spreading Evenly.

When distributing fertilizers or seeds with a Spreader, a greater concentration of product will be found in the center and a lighter spread will occur in the edges of the pattern ① & ②.

In order to obtain a more even spread, you must compensate across the edges of the pattern. The most effective way is to drive the tractor, on the return trip, as close as possible to the outer edge of the previous pattern ③ & ④.

ATTENTION

Cleaning and Greasing

Humid fertilizers harden quickly and may prevent a smooth operation of the regulator disc. It is therefore recommended that the Spreader be cleaned out and washed after each use.

- Close the regulating disc and operate the Spreader slowly while washing the hopper on the inside.
- Open the regulator disc and wash the disc and stirring device while operating slowly.
- Disengage the PTO shaft and remove the hopper from the frame.
- Spray the outside of the Spreader clean.
- Close the regulating disc and lubricate the disc (even waste oil may be used).

- Apply grease to all greasing nipples and make sure that the PTO shaft tubes are cleaned and greased after approximately each 10 hour operating period.

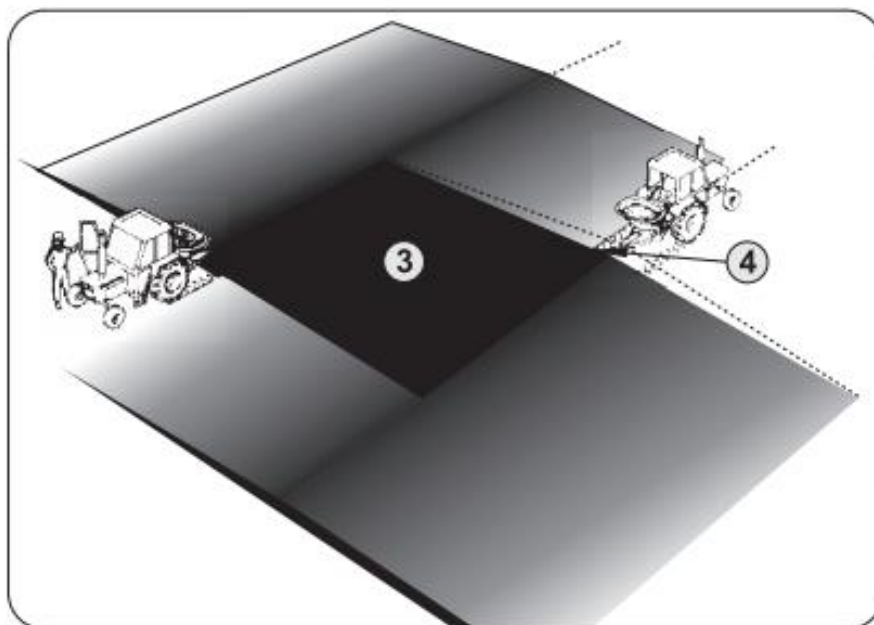
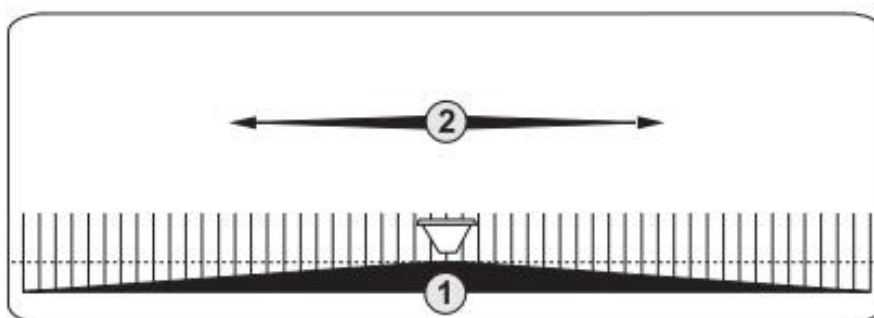

10. Pendulum-action unit with adjustment for distribution width.

The adjustment is carried out at the locking position of the eccentric bearing at the flywheel (see picture below). The flywheel has four locking positions for the eccentric bearing. With a pendulum of the same length, locking the eccentric bearing at position **1** corresponds to the maximum length of distribution, and locking it at position **4** corresponds to the minimum length. Please see pictures below:

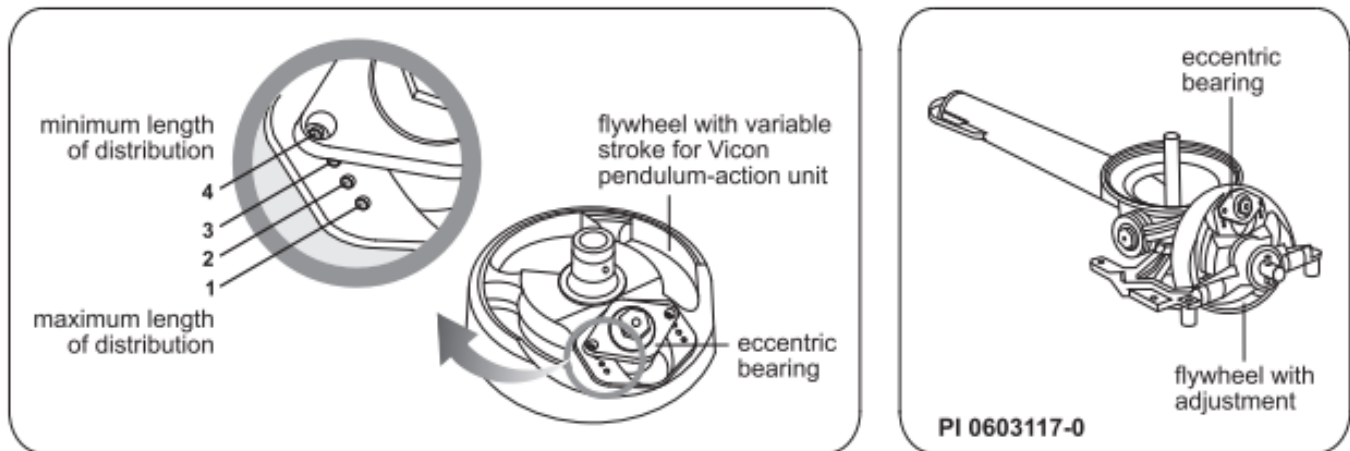

To change the eccentric bearing from one position to another requires:

- 1 - Assemble the machine on the hydraulic leveling system (three points) at tractor.
- 2 - Manually rotate flywheel to position bearing downwards facing the soil.
- 3 - Change position loosening the two bolts that lock eccentric bearing to the flywheel.
- 4 - Take bearing into the required position until the desired distance is reached (positions 1, 2, 3 or 4).
- 5 - Insert bolts and tighten them.

For using the Variable Distribution system efficiently it is essential to cut the pendulum taking into consideration the maximum inter-row distance, where agricultural materials will be applied. For example, if the maximum inter-row distance is 3,5 meters, the pendulum should be cut with the eccentric bearing locked at hole 1 in the flywheel. This procedure is recommended to facilitate gradually reducing distribution width, when the eccentric bearing is locked at holes number 2, 3 or 4, for narrower distances, according to the need. Please see pictures above for reference.

In view of the variety of fertilizers available which feature different physical characteristics, such as granulation, specific weight, fluidity, and some properties of these fertilizers suffer the influence of several variables, such as relative humidity, it is difficult to state precise pendulum sizes and locking positions for eccentric bearing at the flywheel for reaching a predefined distance. It would be impracticable to test this great variety of fertilizer types in the most variable conditions and build tables.

By experience with the most commonly used fertilizers, it was possible to determine the basic behaviors for the distribution width changes depending on the eccentric bearing position.

With the eccentric bearing locked at position 1, the pendulum is cut until it reaches the maximum inter-row distance, where agricultural materials will be distributed. According to field tests, when the eccentric bearing is locked at positions 2, 3 and 4 respectively at the flywheel, distribution width is gradually reduced in 10% from one position to another. (This result was dependent on each agricultural material type distributed, but all of them got approximately the same 10% result used as a reference only. So it is highly recommended that tests and evaluations are performed under real conditions for specific distributions).

Please see picture on opposite page.

With the eccentric bearing locked at position 1 at the flywheel and for a maximum inter-row distance of 3,50 meters, the pendulum was cut until it reached this distribution width. When the pendulum length was defined, the eccentric bearing was locked at the four positions, resulting in the following distribution lengths.

10. Pendulum-action unit with adjustment for distribution width.

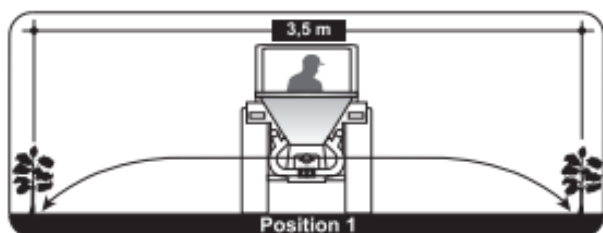

Position 1

Distance of 3,50 meters = 100%.
Desired maximum width for distribution.

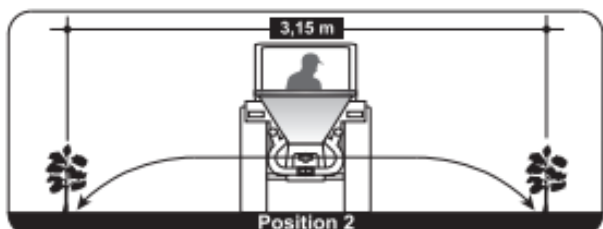

Position 2

Distance of 3,15 meters = 90% from 3,50 meters.

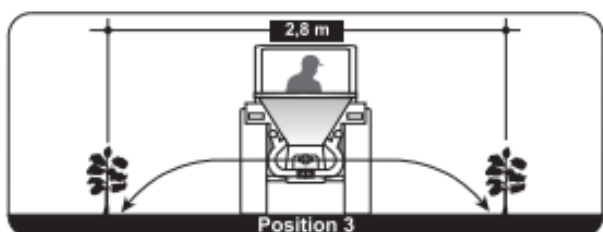

Position 3

Distance of 2,80 meters = 80% from 3,50 meters.

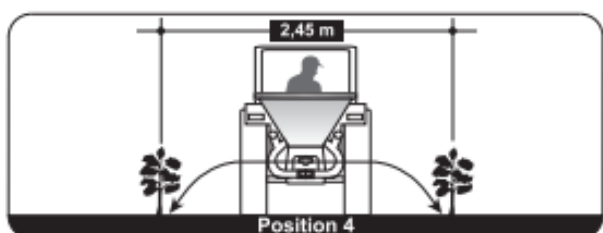

Position 4

Distance of 2,45 meters = 70% from 3,50 meters.

11. Calibration Charts. How to Regulate the Spreader.

With the PTO shaft operating at 540 rpm the amount of fertilizer spread per acre depends on three factors:

- The setting of the adjuster arm, the tractor speed and the width of the spread pattern.
- The spread width varies according to the type of material being used.
- The following charts are meant as a guide but, considering the cost of fertiliser, it is imperative to check the accuracy of the setting as follows:

Example

To spread L.A.N. at 178 lb per hectare at a speed of 19,80 lb/min. with a working width of 19.7 feet.

The table on page 23 shows an adjuster setting of 24.

To check this, remove the pendulum spreader spout. Put a bucket under the opening. With fertilizer in the hopper, run the spreader at 540 r.p.m. with the adjuster set at N° 24 and open the feed gate for one minute. The chart shows that 39,60 lb of material should have flowed into the bucket. If you have more than 39,60 lb close the adjuster a little; if less, open it.

Adjust the arm until you have discharged exactly the correct weight in one minute and then write down the setting for future use.

1. Instrucciones de Seguridad	2
2. Datos Técnicos	13 - 14
3. Información General	14
4. Embalaje y Montaje	15
5. Montaje de la Abonadora sobre el Tractor	16
6. Acoplamiento al eje Toma Fuerza	17
7. Regulación de la Abonadora	18
8. Regulación para el Esparcimiento en Faja	19
9. Esparcimiento Uniforme	20
Limpieza y Engrase	20
10. Unidad pendular con ajuste de inclinación del ancho de distribución	21 - 22
11. Tablas de Calibración. Regulación de la Abonadora	22
L.A.N. 26% Nitrógeno	23 - 24
Nitrato de Potasio Granulado	24 - 26
NPK Grueso 12-10-18	26 - 27
NPK Fino 23-23-0	28 - 29
Superfosfato 19%	29 - 31
K.C.L. 60	31 - 32
Cal Agrícola con agitador	32
Semilla de Rye Grass con agitador	33
Semilla de Trigo	33
12. Catálogo de Piezas y Repuestos - Serie 22400:	
Unidad de la Abonadora	34
Unidad de la Abonadora	35
Unidad de la Abonadora	36
Chasis y Tolva: PS 203, PS 303	37
Chasis y Tolva: PS 403S, PS 503S, PS 603S	38
Chasis y Tolva: PS 753, PS 953, PS 1153, PS 1353, PS 1553T	39
Cables: PS 603S, PS 753/Carreta	40
Carreta: PS 1353T, PS 1553T	41

Español

2. Datos Técnicos.



Modelos	PS 203	PS 303	PS 403S	PS 503S
Capacidad de la tolva (litros)	200	300	400	500
Peso vacío (kg)	89	100	109	115
Altura (cm)	77	92	98	110
Anchura (cm)	90	103	145	145
Anchura EFECTIVA de trabajo	llega a 14 metros			
Rotación	540 RPM			
Rotación de la tasa de siembra	10 - 2000 kg/ha			
Neumáticos	-	-	-	-

Los equipos están sujetos a alteraciones sin previo aviso.
 Los datos informados en la tabla pueden variar de acuerdo con el grado de humedad, peso, tipo

3. Información General.

El **Abonadora Pendular** fue desarrollada para esparcir abono perlado (prilled), cal, polvos y semillas con absoluta precisión.

Para abonar culturas en línea tales como café, cítricos y otros frutales, todo lo que se necesita es cambiar el Tubo Pendular (07665) estándar por el Tubo Pendular (70445) especial, y el abono se esparce en dos fajas definidas, próximas a las plantas o árboles.

La distancia entre las fajas varía según la largura del Tubo Pendular (consulte la tabla ⑤ página 19).

La parte mecánica de todas las Abonadoras son iguales, con alteraciones sólo en cuanto a la capacidad de la tolva, que varía de 300 a 1.500 kilos, dependiendo de la necesidad del usuario y del tractor disponible en la propiedad.

La anchura de trabajo varía de 6 a 14 metros, dependiendo del peso y tipo del material usado en el esparcimiento.

El Abonadora Pendular está equipado con un agitador estándar (piezas 21142 y 21406), que garantiza un patrón uniforme de esparcimiento, independiente del material en uso estar seco, en polvo o granulado.

Si el material está húmedo o endurecido, tal como la cal, yeso y fertilizantes higroscópico, se necesita un agitador especial (piezas 15445 y 36180).

Si tiene dudas o preguntas, por favor contacte nuestro Departamento de Servicio Técnico.

2. Datos Técnicos.



PS 603S	PS 753	PS 953	PS 1153	PS 1353	PS 1553T
600	750	950	1150	1350	1550
120	151	160	170	185	360
129	98	110	120	127	179
145	180	180	180	180	180
llega a 14 metros					
540 RPM					
10 - 2000 kg/ha					
-	-	-	-	-	600 x 16 o 900 x 16

de material y condiciones de trabajo.

3. Embalaje y Montaje.

La Abonadora está parcialmente desmontada para el transporte, por consiguiente las siguientes piezas deben ser montadas en el local:

- La unidad del Tubo Pendular.
- La tolva y las tres chapas de soporte para la armazón tubular.
- La palanca del disco regulador.

El Tubo Pendular

Para montar el Tubo, se necesitará:

- Dos tornillos de rosca fina con tuercas y cuatro arandelas,
- Flange de aluminio (83262) para fijar el Tubo al armazón.

Para montar:

1. Coloque el flange (1) alrededor del Tubo de la Abonadora,
2. Insiera los tornillos y arandelas (2) y (3).
3. Apriete las tuercas utilizando la fuerza de torsión correcta (por ejemplo, 160 Nm/16 kgfm).

Se recomienda mantener la fuerza correcta para evitar daños al cuello del Tubo y al acoplamiento.

La Tolva

La Tolva (7) se fija a la armazón a través de tres chapas reforzadas de tal manera que se pueda quitar fácilmente para limpiarla (4) y (6). (Consulte la página 20).

- Fije las tres chapas de montaje a la armazón, usando 16 tornillos (8), a través de los orificios anteriormente perforados.
- Las cabezas lisas de los tornillos deben estar para el interior de la Tolva (5).
- Para el modelo PS 603S, monte la extensión de 200 lt. (9) encima de la Tolva.

La Barra del Regulador

Para montar la barra del regulador, usted necesitará:

- Prender el medidor a la extremidad plana de la palanca,
- Encajar la palanca en la ranura y préndalo con un pasador.

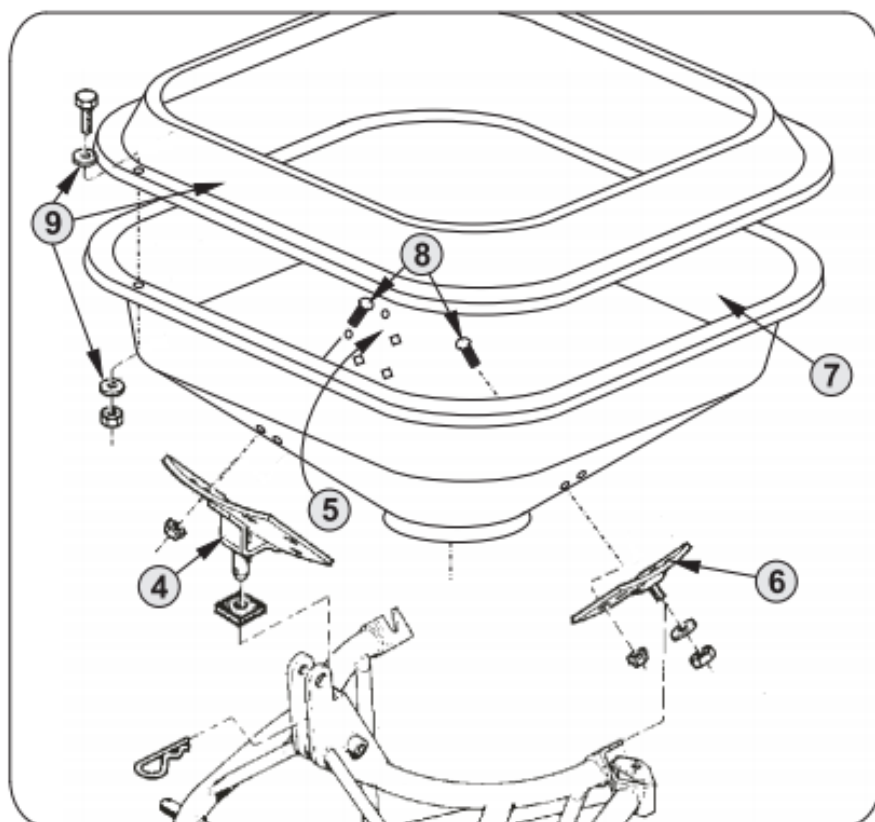
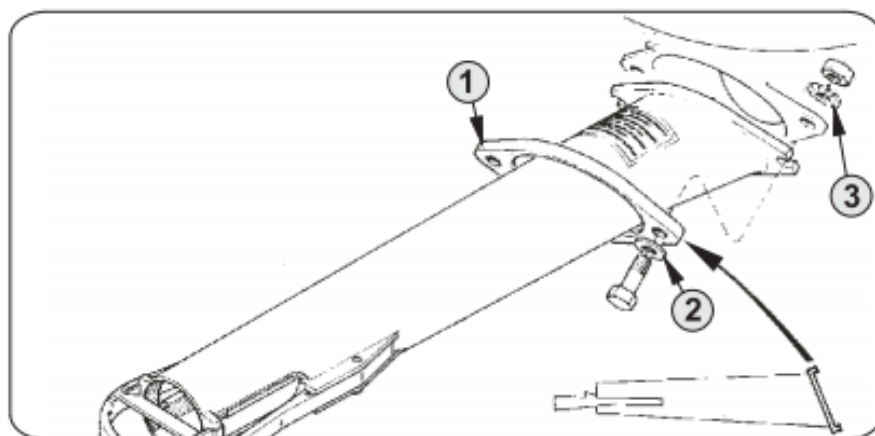

5. Montaje de la Abonadora sobre el Tractor.

Básicamente, la Abonadora Pendular puede acoplarse a cualquier tractor que esté equipado con un elevador hidráulico.

Es importante que el enganche superior en la Abonadora, montada en los de tres puntos del tractor, tenga un juego máximo de 5 cm para evitar el contacto de las dos conexiones laterales (3) con los neumáticos del tractor. Se recomienda el uso de barras estabilizadoras o cadenas.

Como medida adicional de seguridad, se recomienda proteger el eje toma fuerza del tractor con una capa de protección.

Las clavijas de enganche de la Abonadora fueron desarrolladas para las categorías I y II (1) y (2).

Al verlo de frente como de lado, es importante que la Abonadora esté en la posición horizontal (4) y el Tubo Pendular a 75 cm del suelo. (5)

Si fuera usado en un tractor liviano, es aconsejable utilizar lastres frontales en el tractor.

Español

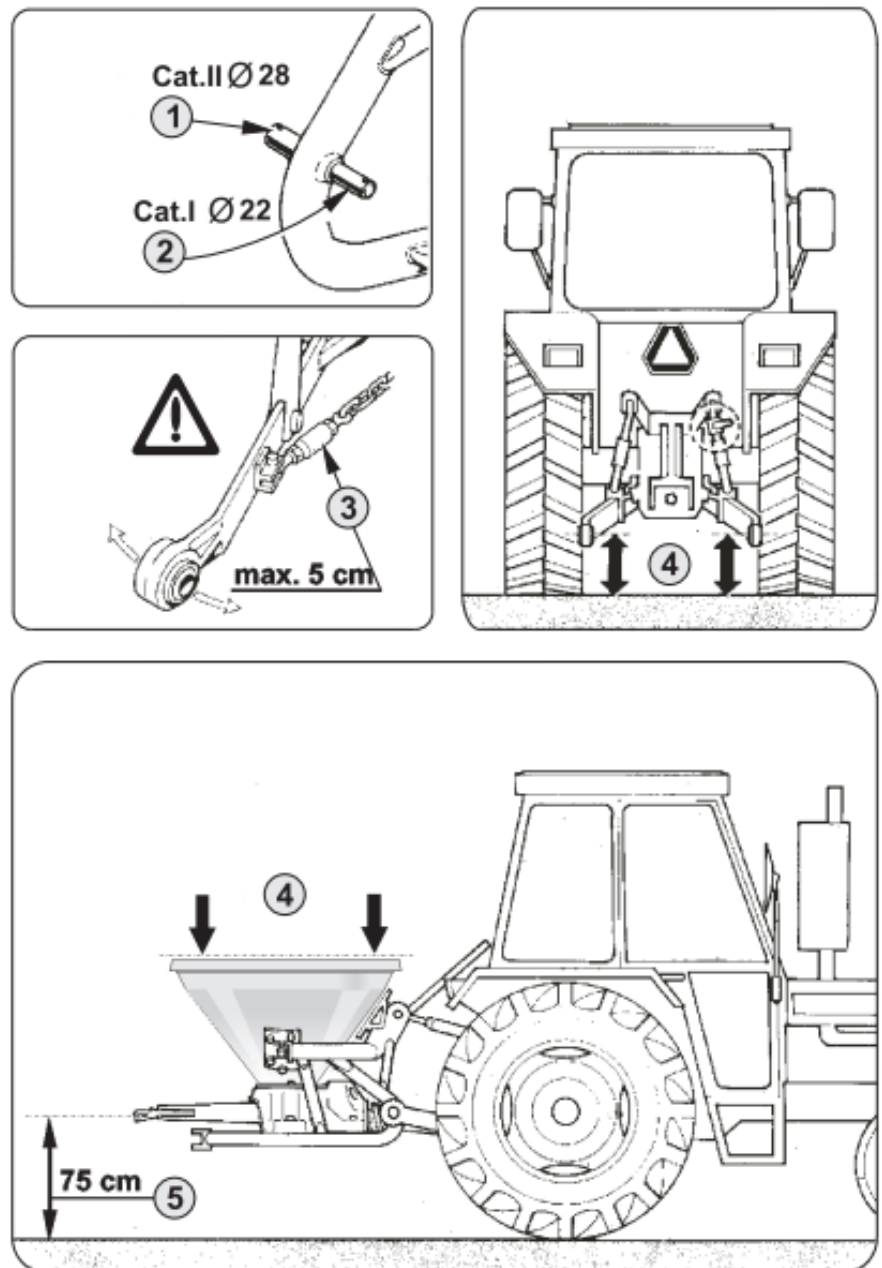

6. Acoplamiento al eje Toma Fuerza.

Levante la Abonadora hasta que el árbol de transmisión alcance la altura del eje toma fuerza del tractor (1).

Conecte la mitad del árbol de transmisión al tractor y la otra mitad a la Abonadora, asegurándolo por los dos lados (2).

Verifique que ambos tubos tengan una diferencia de, por lo menos, 25 mm (1") (3).

Si el árbol de transmisión es muy largo, primero corte los tubos de protección y después los perfiles en la longitud correcta (4) y (5).

Remueva las rebabas, limpie bien y engrase nuevamente el tubo interno en su parte externa.

NOTA: El ángulo del eje toma fuerza no debe exceder 30° (6).

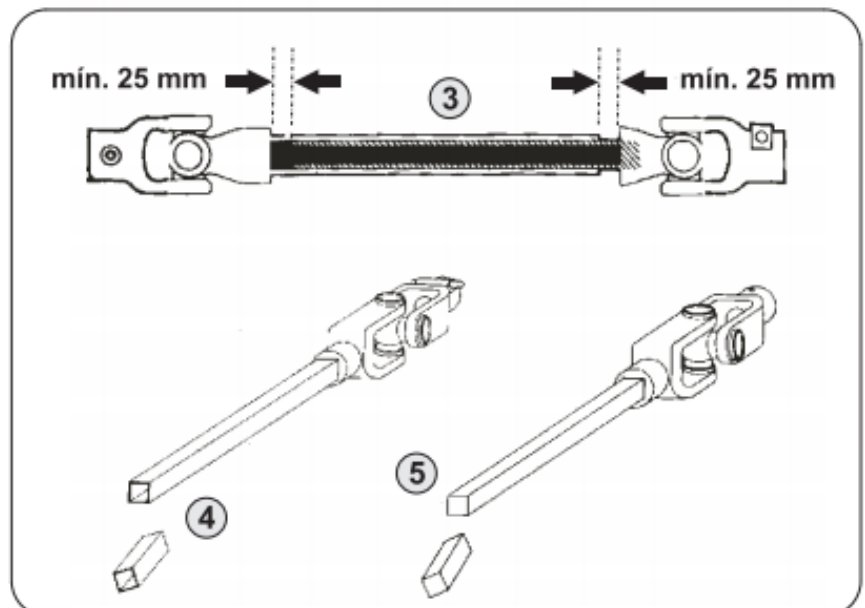
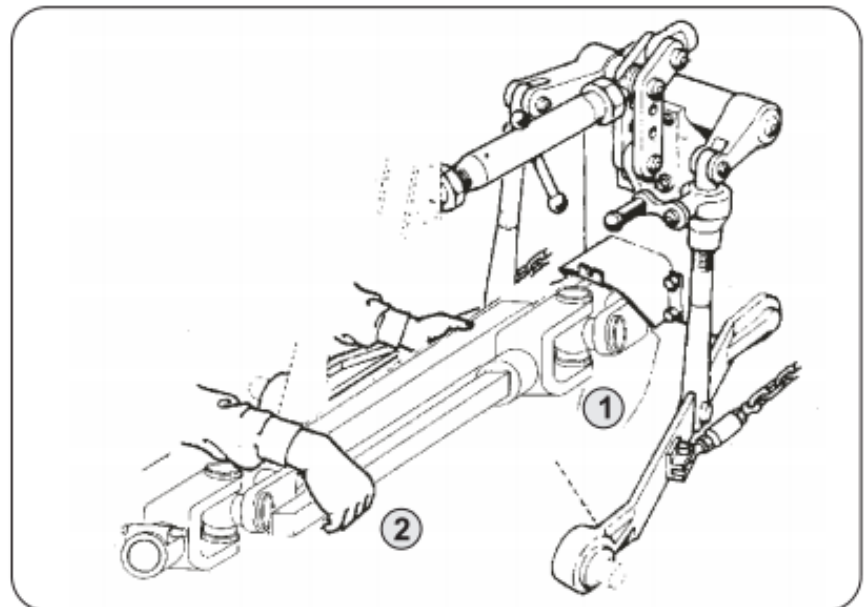
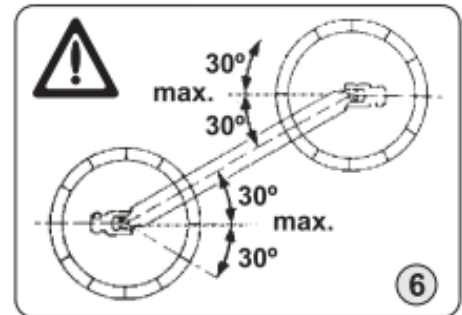

7. Regulación de la Abonadora.

Con una revolución de operación de 540 rpm, la salida del material a esparcir depende de dos factores: la abertura del regulador del volumen de distribución y de la velocidad del tractor.

Aún, por medidas de economía, es muy importante esparcir la cantidad correcta de producto, según el tipo de cultura y de la necesidad del suelo. Antes de esparcir, se debe regular la Abonadora con precisión. A continuación, hay ejemplos detallados para el esparcimiento del abono a 60 kg/acre y la manera para distribuir 50g por árbol a través del esparcimiento por faja.

Ejemplo 1: Esparcimiento 60 kg/acre

A. $60 \text{ kg/acre} = 60.000 \text{ g} / 4.000\text{m}^2 = 15 \text{ g} / \text{m}^2$,

B. Si el tractor trabaja a una velocidad de 6 kph = 6.000 m en 60 min. = 100 m/min.,

C. Medimos la anchura del patrón de esparcimiento, por ejemplo, 8m.,

D. Ahora se sabe que en un minuto es posible abonar $8 \times 100 = 800 \text{ m}^2$, y $800 \times 15 \text{ g}$ (ítem A) es 12.000 g = 12 kg debe ser liberado por la Abonadora, por minuto (consulte también la página 20).

Con este resultado de 12 kg/min., es posible regular la Abonadora del siguiente modo:

- Desconecte el Tubo Pendular de la Abonadora. ①
- Coloque un balde debajo de la abertura. ②
- Cierre el disco del regulador. ③
- Coloque el regulador de nylon en la posición correcta. ④
- Llene la tolva con abono perlado (prills), inicie y acelere el toma fuerza a 540 rpm. ⑤
- Abra el disco del regulador durante un minuto y pese la cantidad de abono colectado. Si el peso es inferior a los 12 kg, abra más el regulador. Si la cantidad es superior a los 12 kg ⑥, cierre el regulador hasta lograr la cantidad correcta. Observe las posiciones correctas para uso futuro.

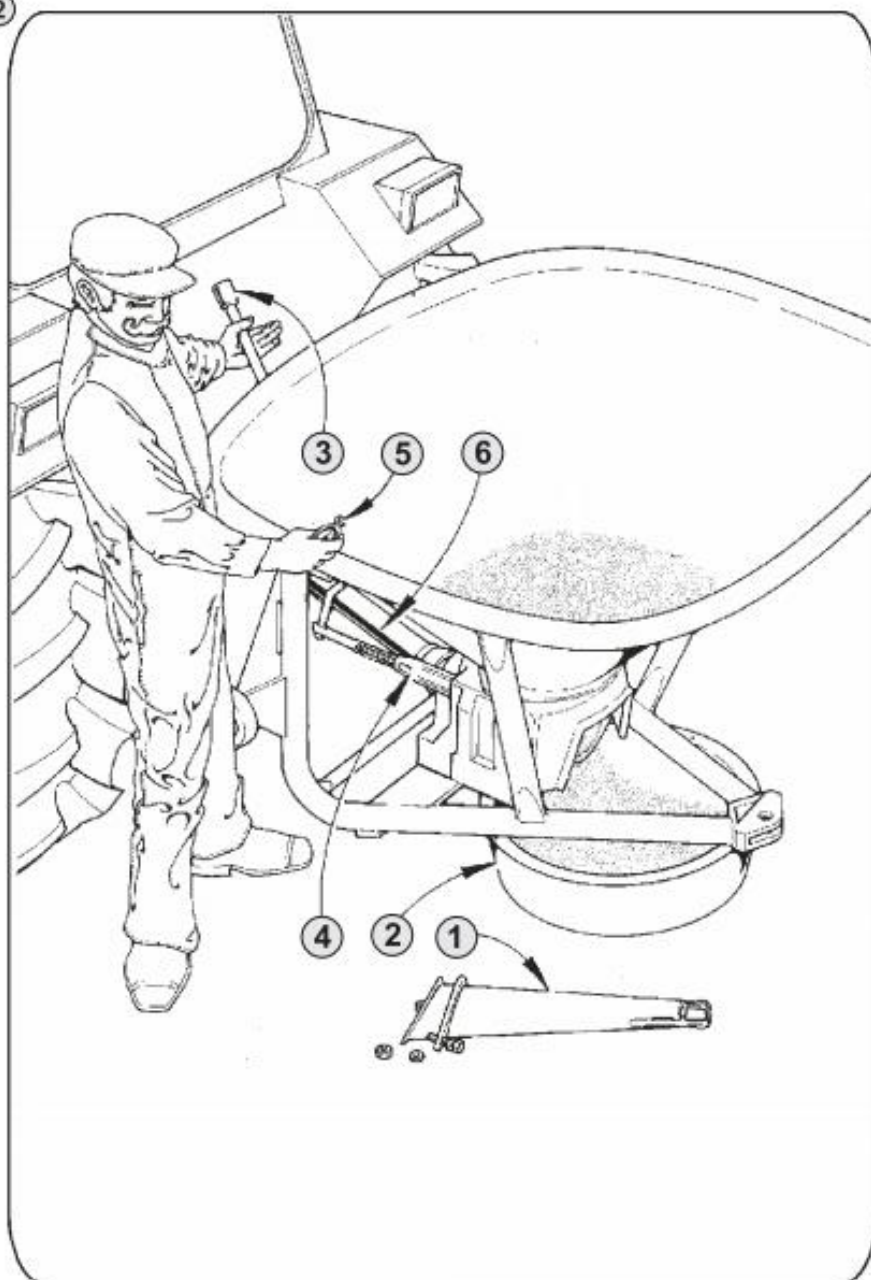

8. Regulación para el Esparcimiento en Faja.

Ejemplo 2: Esparcimiento de 50 g por árbol:

- A. Considere que la cultura está plantada a intervalos de 1,5 m con anchura de 4m entre las líneas. ①
- B. Si el tractor se mueve a 6 kph - 6.000 m en 60 min. = 100 m por minuto.
- C. A cada 100 metros, trabaja 66 árboles por lado = total de 132 árboles.
- D. Con el objetivo de abonar cada árbol con 50 g, se sabe que el volumen de distribución deberá ser $132 \times 50 = 6.600$ kg. Ahora es posible regular la Abonadora como en el ejemplo anterior.

Para esparcir en dos fajas, sustituya el Tubo Pendular estándar (07665) por el Tubo especial (70445). Dependiendo de la largura del Tubo Pendular (70445), la distancia máxima entre las líneas irá variar (consulte la tabla ⑤).

Además del agitador estándar que viene con la Abonadora, proporcionamos un agitador extra ② para ser utilizado con abono húmedo o endurecido. ④

Al montar el agitador, verifique si no tiene juego.

AVISO: Nunca use el agitador extra ② con abono granulado ③ o semillas para no causarles daños.

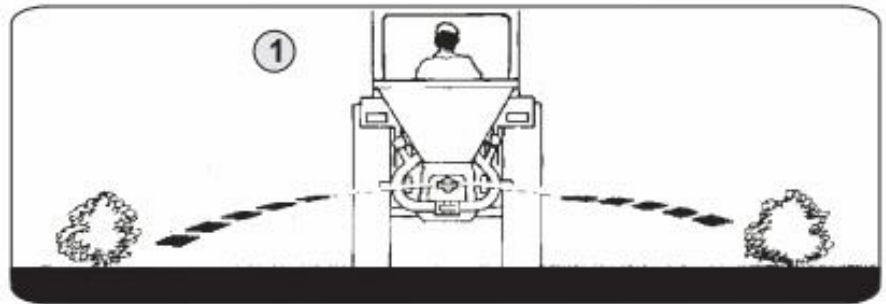

⑤

500 mm	8,5 - 9 m
350 mm	7,5 - 8 m
250 mm	5 - 5,5 m
195 mm	4 - 4,5 m
80 mm	3 - 4 m

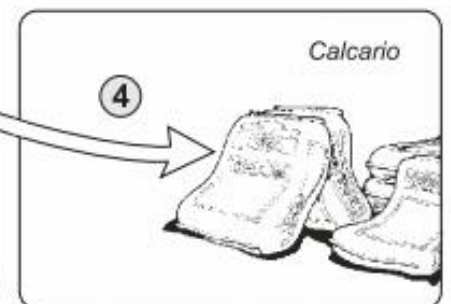
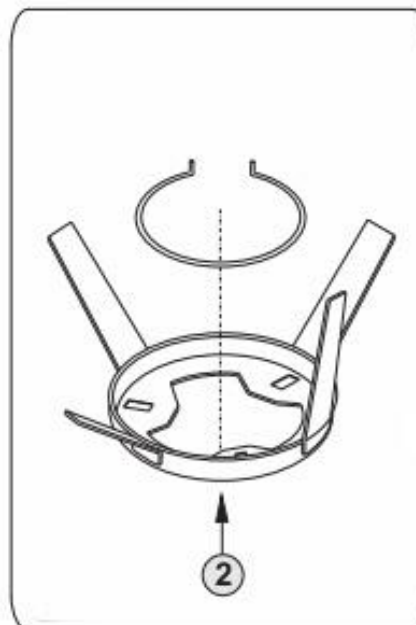

9. Esparcimiento Uniforme.

Al distribuir los abonos o semillas con una Abonadora, habrá siempre una concentración mayor del producto en el centro y la menor en los bordes del patrón ① y ②.

Para obtener un esparcimiento más uniforme, será necesario compensar los bordes del patrón. La manera más eficiente es, al retornar el tractor, arrimarlo lo más próximo posible del borde externo del esparcido anterior ③ y ④.

ATENCIÓN

Limpieza y Engrase

Los abonos húmedos endurecen rápidamente y pueden impedir una operación suave del disco del regulador. Por lo tanto, se recomienda la limpieza y el lavado de la Abonadora después de cada trabajo.

- Cierre el disco del regulador y haga funcionar la Abonadora lentamente mientras lava la parte interna de la tolva.
- Abra el disco del regulador y lave el disco y el agitador mientras funciona lentamente.
- Desenganche el eje toma fuerza y remueva la tolva de la armazón.
- Vaporice la parte externa de la Abonadora limpia.
- Cierre el disco del regulador y engráselo (es posible usar aceite usado).

- Aplique grasa en todos los engrasadores y verifique si los tubos del árbol de transmisión están limpios y con grasa, a cada de 10 horas de trabajo.

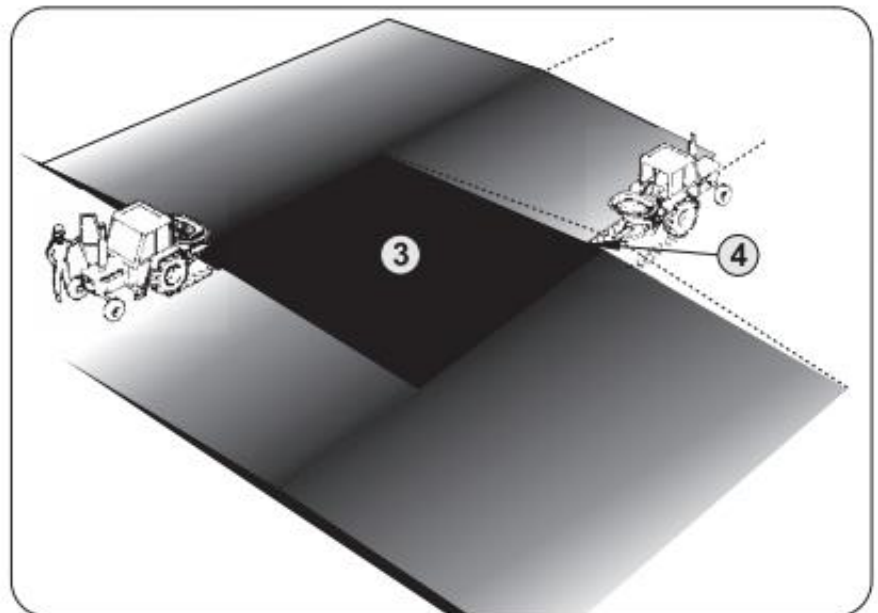
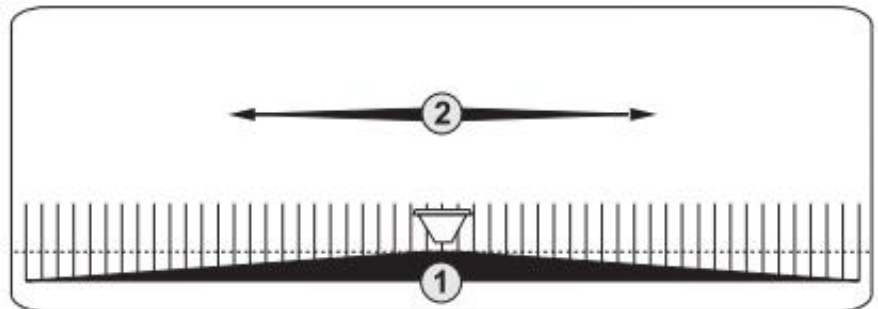

10. Unidad pendular con ajuste de inclinación del ancho de distribución.

El ajuste es realizado en la posición de fijación del rodamiento excéntrico en el volante (figura abajo). El volante posee 4 (cuatro) posiciones de fijación del rodamiento excéntrico, mas todos con un mismo tamaño de longitud del péndulo, si el rodamiento excéntrico es fijado en la posición 1 la máquina estará haciendo uso de su mayor anchura de distribución. No obstante, si el mancal excéntrico es fijado en la posición 4, la máquina hará uso de su menor anchura de distribución. Ver figura abajo:

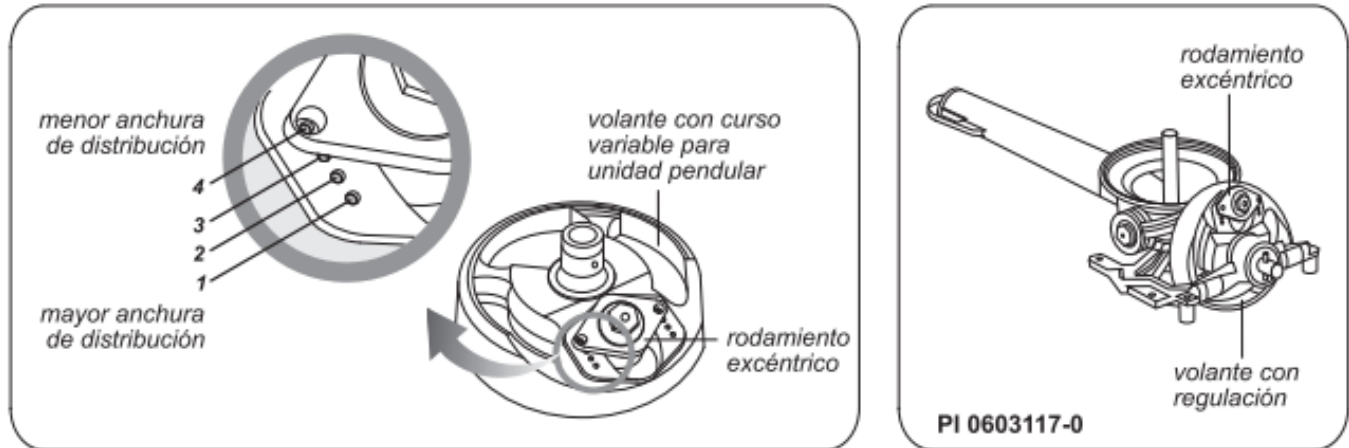

Para realizar el cambio de una posición a otra del rodamiento excéntrico, se debe proceder lo siguiente:

- 1 - Montar la máquina en el elevador hidráulico (tres puntos) del tractor.
- 2 - Girar la manija manualmente de tal forma que el rodamiento se posicione para abajo en dirección al suelo.
- 3 - Hacer el cambio de posición, soltando los dos tornillos que sujetan el rodamiento excéntrico al volante.
- 4 - Llevar el rodamiento hasta la posición deseada que se quiere lograr la distancia requerida (posiciones 1, 2, 3 ó 4).
- 5 - Poner los tornillos y apretarlos.

Para hacer un buen uso con eficiencia del sistema de distribución es muy importante que el corte del péndulo sea efectuado teniendo como objetivo la mayor distancia entre las hileras donde serán aplicados los insumos, por ejemplo, si la mayor distancia entre las hileras es de 3,5 metros, el corte del péndulo debe ser efectuado cuando el rodamiento excéntrico esta fijado en el agujero de posición 1 (uno) del volante y el corte será hecho para que la anchura de distribución alcance los 3,5 metros. Esta colocación es recomendada para que con el corte del péndulo efectuado sea para la mayor distancia, se puede disminuir esta anchura tan solo fijando el rodamiento excéntrico en los agujeros de los números 2, 3 ó 4 (que disminuyen gradualmente la anchura de distribución) obteniéndose anchuras menores de distribución, si es necesario. Las figuras de arriba muestran estas situaciones.

Como existe una grande variedad de fertilizantes que presentan características físicas individuales (granulometría, densidad, consistencia y fluidez) y como algunas propiedades de estos fertilizantes son influenciadas por diversas variables, como por ejemplo: la humedad relativa, es difícil afirmar cuales serán las medidas del péndulo o la posición de sujeción del rodamiento excéntrico en el volante para obtener una distancia predeterminada, porque sería imposible de probar esa grande variedad de tipos de fertilizantes en las diversas condiciones para generar tablas, mismo en grande número no daría cobertura de forma alguna las diferentes situaciones encontradas en el campo.

Para indicar un camino viable, a través de nuestras experiencias con los fertilizantes más usuales, se realizó una previsión tomando como base la alteración de la anchura de distribución con respecto a la posición del rodamiento excéntrico.

Fijando el rodamiento excéntrico en la posición del número 1, cortase el péndulo hasta que obtenga la mayor distancia entre las hileras en el cual se distribuirá el insumo. De acuerdo a las pruebas de campo mostraron, que cuando el rodamiento excéntrico es fijado en las posiciones de número 2, 3 y 4 respectivamente en el volante, la anchura de distribución disminuye gradualmente en 10% para cada posición (ese resultado depende de cada tipo de insumo distribuido, mas todos se acercan a éste mismo resultado de 10% que sirve como base, de esa forma nada es más preciso y lógico que las pruebas y evaluaciones realizados en las condiciones reales de las distribuciones específicas).

En la página siguiente son ilustrados los ejemplos citados:

Con el rodamiento fijado en la posición 1 del volante, para un espaciamiento máximo de 3,5 metros entre las hileras fue cortado el péndulo hasta que obtener la anchura de distribución. Una vez que se haya determinado el largo del péndulo es mantenido, luego es fijado el rodamiento excéntrico en las cuatro posiciones obteniéndose las siguientes anchuras de distribución:

10. Unidad pendular con ajuste de inclinación del ancho de distribución.

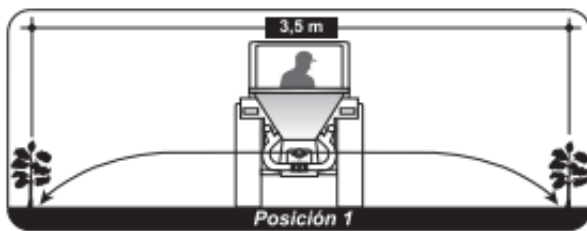

Posición 1

Distancia de 3,50 metros igual al 100%.
Máxima anchura de distribución establecida.

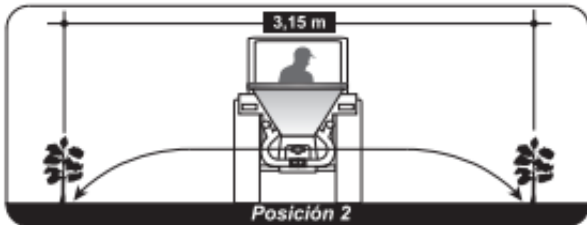

Posición 2

Distancia de 3,15 m igual al 90% del total de 3,50 metros.

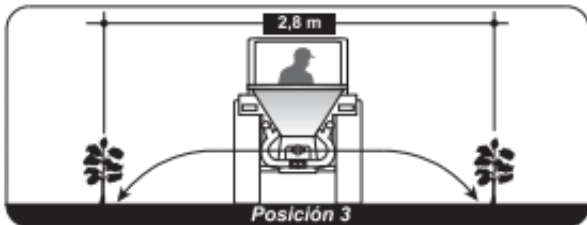

Posición 3

Distancia de 2,80 m igual al 80% del total de 3,50 metros.



Posición 4

Distancia de 2,45 m igual al 70% del total de 3,50 metros.

11. Tablas de Calibración. Regulación de la Abonadora.

Con el eje toma fuerza funcionando a 540 rpm, la cantidad de abono esparcido por hectárea depende de tres factores:

- La posición de la palanca del regulador, la velocidad del tractor y la anchura del patrón de esparcimiento.
- La anchura de esparcimiento varía según el tipo de material.
- Las siguientes tablas sirven como orientación pero, considerando el costo del abono, es imperativo verificar la precisión de la posición, como sigue:

Ejemplo

Para esparcir L.A.N. en 200 kg por hectárea a una velocidad de 9 km/h con una anchura de trabajo de 6 m.

La tabla en la página 23 muestra que la posición del regulador es 24. Para verificar ese dato, remueva el tubo de la Abonadora pendular. Coloque un balde debajo de la abertura. Con el abono en la tolva, haga funcionar la Abonadora a 540 rpm con el regulador en el número 24 y abra la salida del alimentador (el disco del regulador) por un minuto. La tabla muestra que 18 kg de material ha caído al balde. Si hay más de 18 kg, cierre un poco el regulador; si es menos, ábralo. Ajuste el regulador hasta descargar exactamente el peso correcto en un minuto y después registre la posición para uso futuro.

L.A.N. 26% Nitrogen

working width **19.7** FEET

Adjuster setting	Quantity spread lb/min	Tractor Speed mph						
		3,72	4,34	5	5,6	6	7	7,5
		lb/acre						
18	24	163	140	123	109	98	89	82
21	29	193	166	145	128	116	105	96
24	40	267	229	200	178	160	146	134
27	46	312	267	234	208	187	170	156
30	57	386	331	290	257	232	210	193
33	66	446	382	334	297	267	243	223
36	79	535	458	401	357	321	291	267
42	106	713	612	535	475	428	389	356
48	139	936	802	702	624	562	511	468
54	176	1188	1019	892	793	713	648	595

L.A.N 26% Nitrógeno

anchura de trabajo **6** METROS

Posición del regulador	Cantidad esparcida kg/min	Velocidad del Tractor km/h						
		6	7	8	9	10	11	12
		kg por hectárea						
18	11	183	157	138	122	110	100	92
21	13	217	186	163	144	130	118	108
24	18	300	257	225	200	180	164	150
27	21	350	300	263	233	210	191	175
30	26	433	371	325	288	260	236	217
33	30	500	429	375	333	300	273	250
36	36	600	514	450	400	360	327	300
42	48	800	686	600	533	480	436	400
48	63	1050	900	788	700	630	573	525
54	80	1333	1143	1000	889	800	727	667

L.A.N. 26% Nitrogen

working width **29.5** FEET

Adjuster setting	Quantity spread lb/min	Tractor Speed mph						
		3,72	4,34	5	5,6	6	7	7,5
		lb/acre						
18	24	109	94	82	72	65	60	54
21	29	128	110	96	85	77	70	64
24	40	178	152	134	118	107	97	89
27	46	208	178	156	139	125	113	104
30	57	258	221	193	172	154	141	128
33	66	297	255	223	198	178	162	149
36	79	357	306	267	238	214	194	178
42	106	475	407	357	317	285	259	238
48	139	624	535	468	416	374	341	312
54	176	793	679	595	529	475	432	396

L.A.N 26% Nitrógeno

anchura de trabajo **9** METROS

Posición del regulador	Cantidad esparcida kg/min	Velocidad del Tractor km/h						
		6	7	8	9	10	11	12
		kg por hectárea						
18	11	122	105	92	81	73	67	61
21	13	144	124	108	96	87	79	72
24	18	200	171	150	133	120	109	100
27	21	233	200	175	156	140	127	117
30	26	289	248	217	193	173	158	144
33	30	333	286	250	222	200	182	167
36	36	400	343	300	267	240	218	200
42	48	533	457	400	356	320	291	267
48	63	700	600	525	467	420	382	350
54	80	889	762	667	593	533	485	444

L.A.N. 26% Nitrogen

working width **32.8** FEET

Adjuster setting	Quantity spread lb/min	Tractor Speed mph						
		3,72	4,34	5	5,6	6	7	7,5
		lb/acre						
18	24	98	84	74	65	59	53	49
21	29	116	99	87	78	69	62	58
24	40	160	137	120	107	96	83	80
27	46	187	160	141	125	112	103	94
30	57	232	199	174	155	139	127	116
33	66	267	229	201	178	160	146	134
36	79	321	276	241	214	193	175	160
42	106	428	366	321	285	257	233	214
48	139	562	481	422	374	337	307	281
54	176	713	612	535	475	428	388	357

L.A.N 26% Nitrógeno

anchura de trabajo **10** METROS

Posición del regulador	Cantidad esparcida kg/min	Velocidad del Tractor km/h						
		6	7	8	9	10	11	12
		kg por hectárea						
18	11	110	94	83	73	66	60	55
21	13	130	111	98	87	78	70	65
24	18	180	154	135	120	108	97	90
27	21	210	180	158	140	126	115	105
30	26	260	223	195	173	156	142	130
33	30	300	257	225	200	180	164	150
36	36	360	309	270	240	216	196	180
42	48	480	411	360	320	288	262	240
48	63	630	540	473	420	378	344	315
54	80	800	686	600	533	480	436	400

L.A.N. 26% Nitrogen

working width **39.4** FEET

Adjuster setting	Quantity spread lb/min	Tractor Speed mph						
		3,72	4,34	5	5,6	6	7	7,5
		lb/acre						
18	24	82	70	61	55	49	46	41
21	29	96	83	72	64	58	53	48
24	40	134	115	101	89	80	73	67
27	46	156	134	117	104	94	85	78
30	57	193	166	145	128	116	105	96
33	66	223	191	168	149	134	121	111
36	79	267	229	201	178	160	146	134
42	106	357	306	267	238	214	194	178
48	139	468	401	351	312	281	255	234
54	176	595	509	446	396	357	324	297

L.A.N 26% Nitrógeno

anchura de trabajo **12** METROS

Posición del regulador	Cantidad esparcida kg/min	Velocidad del Tractor km/h						
		6	7	8	9	10	11	12
		kg por hectárea						
18	11	92	79	69	61	55	50	46
21	13	108	93	81	72	65	59	54
24	18	150	129	113	100	90	82	75
27	21	175	150	131	117	105	95	88
30	26	217	186	163	144	130	118	108
33	30	250	214	188	167	150	136	125
36	36	300	257	225	200	180	164	150
42	48	400	343	300	267	240	218	200
48	63	525	450	394	350	315	286	263
54	80	667	571	500	444	400	364	333

L.A.N. 26% Nitrogen

working width **46** FEET

Adjuster setting	Quantity spread lb/min	Tractor Speed mph						
		3,72	4,34	5	5,6	6	7	7,5
		lb/acre						
18	24	70	60	53	46	42	38	35
21	29	83	71	62	56	50	45	41
24	40	115	98	86	77	69	62	57
27	46	134	115	101	89	80	73	67
30	57	166	142	124	110	99	90	83
33	66	191	164	143	128	115	104	95
36	79	229	196	172	152	137	125	115
42	106	306	262	229	195	184	167	152
48	139	401	344	301	267	241	218	201
54	176	509	437	382	340	306	278	255

L.A.N 26% Nitrógeno

anchura de trabajo **14** METROS

Posición del regulador	Cantidad esparcida kg/min	Velocidad del Tractor km/h						
		6	7	8	9	10	11	12
		kg por hectárea						
18	11	79	67	59	52	47	43	39
21	13	93	80	70	62	56	51	46
24	18	129	110	96	86	77	70	64
27	21	150	129	113	100	90	82	75
30	26	186	159	139	124	111	101	93
33	30	214	184	161	143	129	117	107
36	36	257	220	193	171	154	140	129
42	48	343	294	257	219	206	187	171
48	63	450	386	338	300	270	245	225
54	80	571	490	429	381	343	312	286

Potassium Nitrate Granules

working width **19.7** FEET

Adjuster setting	Quantity spread lb/min	Tractor Speed mph						
		3,72	4,34	5	5,6	6	7	7,5
		lb/acre						
18	24	163	140	123	109	98	89	82
21	35	238	204	178	159	143	129	118
24	48	327	280	245	218	196	178	163
27	64	430	369	324	287	258	235	215
30	77	520	446	390	347	312	284	260
33	90	609	522	457	407	365	332	305
36	108	728	624	546	485	436	397	364
42	134	907	776	680	604	544	495	453
48	163	1099	942	825	733	660	600	550
54	202	1367	1172	1025	911	820	745	684

Nitrato de Potasio Granulado

anchura de trabajo **6** METROS

Posición del regulador	Cantidad esparcida kg/min	Velocidad del Tractor km/h						
		6	7	8	9	10	11	12
		kg por hectárea						
18	11	183	157	138	122	110	100	92
21	16	267	229	200	178	160	145	133
24	22	367	314	275	244	220	200	183
27	29	483	414	363	322	290	264	242
30	35	583	500	438	389	350	318	292
33	41	683	586	513	456	410	373	342
36	49	817	700	613	544	490	445	408
42	61	1017	871	763	678	610	555	508
48	74	1233	1057	925	822	740	673	617
54	92	1533	1314	1150	1022	920	836	767

Potassium Nitrate Granules

working width **29.5** FEET

Adjuster setting	Quantity spread lb/min	Tractor Speed mph						
		3,72	4,34	5	5,6	6	7	7,5
		lb/acre						
18	24	109	94	82	72	65	60	54
21	35	159	136	119	106	95	86	79
24	48	217	187	163	145	131	119	109
27	64	287	246	216	192	172	157	143
30	77	347	297	260	231	208	189	173
33	90	406	348	305	271	243	221	203
36	108	485	416	364	324	291	265	242
42	134	604	518	453	403	363	330	302
48	163	733	628	550	489	439	399	366
54	202	911	781	684	607	546	497	456

Nitrato de Potasio Granulado

anchura de trabajo **9** METROS

Posición del regulador	Cantidad esparcida kg/min	Velocidad del Tractor km/h						
		6	7	8	9	10	11	12
		kg por hectárea						
18	11	122	105	92	81	73	67	61
21	16	178	152	133	119	107	97	89
24	22	244	210	183	163	147	133	122
27	29	322	276	242	215	193	176	161
30	35	389	333	292	259	233	212	194
33	41	456	390	342	304	273	248	228
36	49	544	467	408	363	327	297	272
42	61	678	581	508	452	407	370	339
48	74	822	705	617	548	493	448	411
54	92	1022	876	767	681	613	558	511

Potassium Nitrate Granules

working width **32.8** FEET

Adjuster setting	Quantity spread lb/min	Tractor Speed mph						
		3,72	4,34	5	5,6	6	7	7,5
		lb/acre						
18	24	98	84	74	65	59	53	49
21	35	143	122	107	95	86	77	71
24	48	196	168	147	132	117	107	98
27	64	258	222	194	172	155	141	129
30	77	312	267	234	208	187	170	156
33	90	365	313	275	243	219	200	183
36	108	437	374	328	291	262	238	218
42	134	544	466	408	363	326	297	272
48	163	660	565	495	440	396	360	330
54	202	820	703	615	546	492	448	410

Nitrato de Potasio Granulado

anchura de trabajo **10** METROS

Posición del regulador	Cantidad esparcida kg/min	Velocidad del Tractor km/h						
		6	7	8	9	10	11	12
		kg por hectárea						
18	11	110	94	83	73	66	60	55
21	16	160	137	120	107	96	87	80
24	22	220	189	165	147	132	120	110
27	29	290	249	218	193	174	158	145
30	35	350	300	263	233	210	191	175
33	41	410	351	308	273	246	224	205
36	49	490	420	368	327	294	267	245
42	61	610	523	458	407	366	333	305
48	74	740	634	555	493	444	404	370
54	92	920	789	690	613	552	502	460

Potassium Nitrate Granules

working width **39.4** FEET

Adjuster setting	Quantity spread lb/min	Tractor Speed mph						
		3,72	4,34	5	5,6	6	7	7,5
		lb/acre						
18	24	82	70	62	54	49	44	41
21	35	118	102	89	79	71	65	60
24	48	163	140	123	109	98	89	82
27	64	215	185	161	144	129	118	108
30	77	260	223	195	173	156	142	130
33	90	305	261	228	203	183	166	152
36	108	364	312	273	243	218	199	182
42	134	453	389	340	303	272	247	226
48	163	550	472	413	366	330	300	275
54	202	684	586	513	456	410	373	341

Nitrato de Potasio Granulado

anchura de trabajo **12** METROS

Posición del regulador	Cantidad esparcida kg/min	Velocidad del Tractor km/h						
		6	7	8	9	10	11	12
		kg por hectárea						
18	11	92	79	69	61	55	49	46
21	16	133	114	100	89	80	73	67
24	22	183	157	138	122	110	100	92
27	29	242	207	181	161	145	132	121
30	35	292	250	219	194	175	159	146
33	41	342	293	256	228	205	186	171
36	49	408	350	306	272	245	223	204
42	61	508	436	381	339	305	277	254
48	74	617	529	463	411	370	336	308
54	92	767	657	575	511	460	418	383

Potassium Nitrate Granules**working width** **46** FEET

Adjuster setting Quantity spread lb/min	Tractor Speed mph							
	3,72	4,34	5	5,6	6	7	7,5	
	lb/acre							
18	24	70	60	53	47	42	38	35
21	35	102	87	77	67	62	55	51
24	48	140	120	105	94	84	77	70
27	64	185	159	138	123	111	101	93
30	77	223	191	168	149	134	121	111
33	90	261	224	196	174	157	143	130
36	108	312	267	234	208	187	170	156
42	134	389	333	292	259	233	212	194
48	163	472	404	353	314	283	257	235
54	202	586	502	440	390	351	320	293

Nitrato de Potasio Granulado**anchura de trabajo** **14** METROS

Posición del regulador Cantidad esparcida kg/min	Velocidad del Tractor km/h							
	6	7	8	9	10	11	12	
	kg por hectárea							
18	11	79	67	59	52	47	43	39
21	16	114	98	86	76	69	62	57
24	22	157	135	118	105	94	86	79
27	29	207	178	155	138	124	113	104
30	35	250	214	188	167	150	136	125
33	41	293	251	220	195	176	160	146
36	49	350	300	263	233	210	191	175
42	61	436	373	327	290	261	238	218
48	74	529	453	396	352	317	288	264
54	92	657	563	493	438	394	358	329

NPK Coarse 12 - 10 - 18**working width** **19.7** FEET

Adjuster setting Quantity spread lb/min	Tractor Speed mph							
	3,72	4,34	5	5,6	6	7	7,5	
	lb/acre							
18	24	163	140	123	109	98	89	64
21	28	193	166	145	128	116	105	96
24	39	267	229	201	179	159	146	134
27	46	312	267	234	208	187	170	156
30	57	386	331	290	258	232	210	193
33	66	446	382	334	297	267	243	223
36	79	535	458	401	357	321	292	267
42	106	713	612	535	475	428	389	357
48	139	936	802	703	624	562	511	468
54	176	1188	1019	892	793	713	648	595

NPK Grueso 12 - 10 - 18**anchura de trabajo** **6** METROS

Posición del regulador Cantidad esparcida kg/min	Velocidad del Tractor km/h							
	6	7	8	9	10	11	12	
	kg por hectárea							
18	11	183	157	138	122	110	100	72
21	13	217	186	163	144	130	118	108
24	18	300	257	225	200	180	164	150
27	21	350	300	263	233	210	191	175
30	26	433	371	325	289	260	236	217
33	30	500	429	375	333	300	273	250
36	36	600	514	450	400	360	327	300
42	48	800	686	600	533	480	436	400
48	63	1050	900	788	700	630	573	525
54	80	1333	1143	1000	889	800	727	667

NPK Coarse 12 - 10 - 18**working width** **29.5** FEET

Adjuster setting Quantity spread lb/min	Tractor Speed mph							
	3,72	4,34	5	5,6	6	7	7,5	
	lb/acre							
18	24	109	94	82	72	65	60	54
21	28	128	111	96	86	77	70	64
24	39	178	152	134	119	106	97	89
27	46	208	178	156	139	125	113	104
30	57	258	221	193	173	154	141	128
33	66	297	255	223	198	178	162	149
36	79	357	306	267	238	214	194	178
42	106	475	407	357	318	285	259	238
48	139	624	535	468	416	374	340	312
54	176	793	679	595	529	475	432	396

NPK Grueso 12 - 10 - 18**anchura de trabajo** **9** METROS

Posición del regulador Cantidad esparcida kg/min	Velocidad del Tractor km/h							
	6	7	8	9	10	11	12	
	kg por hectárea							
18	11	122	105	92	81	73	67	61
21	13	144	124	108	96	87	79	72
24	18	200	171	150	133	120	109	100
27	21	233	200	175	156	140	127	117
30	26	289	248	217	193	173	158	144
33	30	333	286	250	222	200	182	167
36	36	400	343	300	267	240	218	200
42	48	533	457	400	356	320	291	267
48	63	700	600	525	467	420	382	350
54	80	889	762	667	593	533	485	444

NPK Coarse 12 - 10 - 18

working width **32.8** FEET

Adjuster setting	Quantity spread lb/min	Tractor Speed mph						
		3,72	4,34	5	5,6	6	7	7,5
		lb/acre						
18	24	98	84	74	65	59	53	49
21	28	116	99	87	78	69	63	58
24	39	160	137	120	107	96	87	80
27	46	187	160	141	125	112	102	94
30	57	232	199	174	155	139	127	116
33	66	267	229	201	179	160	146	134
36	79	321	275	241	214	193	175	160
42	106	428	366	321	285	257	234	214
48	139	562	481	422	374	337	307	281
54	176	713	612	535	475	428	389	357

NPK Grueso 12 - 10 - 18

anchura de trabajo **10** METROS

Posición del regulador	Cantidad esparcida kg/min	Velocidad del Tractor km/h						
		6	7	8	9	10	11	12
		kg por hectárea						
18	11	110	94	83	73	66	60	55
21	13	130	111	98	87	78	71	65
24	18	180	154	135	120	108	98	90
27	21	210	180	158	140	126	115	105
30	26	260	223	195	173	156	142	130
33	30	300	257	225	200	180	164	150
36	36	360	309	270	240	216	196	180
42	48	480	411	360	320	288	262	240
48	63	630	540	473	420	378	344	315
54	80	800	686	600	533	480	436	400

NPK Coarse 12 - 10 - 18

working width **39.4** FEET

Adjuster setting	Quantity spread lb/min	Tractor Speed mph						
		3,72	4,34	5	5,6	6	7	7,5
		lb/acre						
18	24	82	70	61	55	49	45	41
21	28	96	83	72	64	58	53	48
24	39	134	115	101	89	80	73	67
27	46	156	134	117	104	94	85	78
30	57	193	166	145	128	116	105	96
33	66	223	191	168	148	133	121	111
36	79	267	229	201	178	160	146	134
42	106	357	306	267	238	214	194	178
48	139	468	401	351	312	281	255	234
54	176	595	509	446	396	357	324	297

NPK Grueso 12 - 10 - 18

anchura de trabajo **12** METROS

Posición del regulador	Cantidad esparcida kg/min	Velocidad del Tractor km/h						
		6	7	8	9	10	11	12
		kg por hectárea						
18	11	92	79	69	61	55	50	46
21	13	108	93	81	72	65	59	54
24	18	150	129	113	100	90	82	75
27	21	175	150	131	117	105	95	88
30	26	217	186	163	144	130	118	108
33	30	250	214	188	166	150	136	125
36	36	300	257	225	200	180	164	150
42	48	400	343	300	267	240	218	200
48	63	525	450	394	350	315	286	263
54	80	667	571	500	444	400	364	333

NPK Coarse 12 - 10 - 18

working width **46** FEET

Adjuster setting	Quantity spread lb/min	Tractor Speed mph						
		3,72	4,34	5	5,6	6	7	7,5
		lb/acre						
18	24	70	60	53	46	42	38	35
21	28	83	71	62	55	50	45	41
24	39	115	98	86	76	69	62	57
27	46	134	115	101	89	80	73	65
30	57	166	142	124	110	99	90	83
33	66	191	164	144	127	115	104	95
36	79	229	196	172	152	137	125	115
42	106	306	262	229	204	184	167	152
48	139	401	344	301	267	241	218	201
54	176	509	437	382	340	306	278	255

NPK Grueso 12 - 10 - 18

anchura de trabajo **14** METROS

Posición del regulador	Cantidad esparcida kg/min	Velocidad del Tractor km/h						
		6	7	8	9	10	11	12
		kg por hectárea						
18	11	79	67	59	52	47	43	39
21	13	93	80	70	62	56	51	46
24	18	129	110	96	86	77	70	64
27	21	150	129	113	100	90	82	75
30	26	186	159	139	124	111	101	93
33	30	214	184	161	143	129	117	107
36	36	257	220	193	171	154	140	129
42	48	343	294	257	229	206	187	171
48	63	450	386	338	300	270	245	225
54	80	571	490	429	381	343	312	286

NPK Fine 23 - 23 - 0									
working width		19.7		FEET					
Adjuster setting Quantity spread lb/min	Tractor Speed mph								
	3,72	4,34	5	5,6	6	7	7,5		
	lb/acre								
24	26	178	152	134	119	107	97	89	
27	35	238	204	178	159	142	129	119	
30	44	297	255	223	198	178	162	149	
33	55	372	318	279	248	223	202	185	
36	64	431	369	324	287	259	235	216	
42	86	580	497	435	386	348	316	290	
48	110	743	637	557	496	446	406	372	
54	134	906	777	680	605	544	495	453	
60	163	1099	942	825	733	660	600	550	
66	198	1337	1147	1003	892	802	729	669	

NPK Fino 23 - 23 - 0									
anchura de trabajo		6		METROS					
Posición del regulador Cantidad esparcida kg/min	Velocidad del Tractor km/h								
	6	7	8	9	10	11	12		
	kg por hectárea								
24	12	200	171	150	133	120	109	100	
27	16	267	229	200	178	160	145	133	
30	20	333	286	250	222	200	182	167	
33	25	417	357	313	278	250	227	208	
36	29	483	414	363	322	290	264	242	
42	39	650	557	488	433	390	355	325	
48	50	833	714	625	556	500	455	417	
54	61	1014	871	763	678	610	555	508	
60	74	1233	1057	925	822	740	673	617	
66	90	1500	1286	1125	1000	900	818	750	

NPK Fine 23 - 23 - 0									
working width		29.5		FEET					
Adjuster setting Quantity spread lb/min	Tractor Speed mph								
	3,72	4,34	5	5,6	6	7	7,5		
	lb/acre								
24	26	119	102	89	79	71	65	60	
27	35	159	136	119	106	95	86	79	
30	44	198	169	149	132	119	108	99	
33	55	248	212	185	165	149	135	124	
36	64	287	246	216	192	172	157	144	
42	86	386	331	290	258	232	210	193	
48	110	496	424	372	330	297	270	248	
54	134	605	518	453	403	362	330	302	
60	163	733	629	550	489	440	399	366	
66	198	892	764	669	595	535	486	446	

NPK Fino 23 - 23 - 0									
anchura de trabajo		9		METROS					
Posición del regulador Cantidad esparcida kg/min	Velocidad del Tractor km/h								
	6	7	8	9	10	11	12		
	kg por hectárea								
24	12	133	114	100	89	80	73	67	
27	16	178	152	133	119	107	97	89	
30	20	222	190	167	148	133	121	111	
33	25	278	238	208	185	167	152	139	
36	29	322	276	242	215	193	176	161	
42	39	433	371	325	289	260	236	217	
48	50	556	476	417	370	333	303	278	
54	61	678	581	508	452	407	370	339	
60	74	822	705	617	548	493	448	411	
66	90	1000	857	750	667	600	545	500	

NPK Fine 23 - 23 - 0									
working width		32.8		FEET					
Adjuster setting Quantity spread lb/min	Tractor Speed mph								
	3,72	4,34	5	5,6	6	7	7,5		
	lb/acre								
24	26	107	92	80	71	64	58	53	
27	35	143	122	107	95	86	78	71	
30	44	178	152	134	119	107	97	89	
33	55	223	191	168	149	134	121	111	
36	64	286	222	194	172	155	141	129	
42	86	348	258	261	232	209	190	174	
48	110	446	382	334	297	267	243	223	
54	134	544	466	408	363	326	297	272	
60	163	660	565	495	440	396	360	330	
66	198	802	687	602	535	481	438	401	

NPK Fino 23 - 23 - 0									
anchura de trabajo		10		METROS					
Posición del regulador Cantidad esparcida kg/min	Velocidad del Tractor km/h								
	6	7	8	9	10	11	12		
	kg por hectárea								
24	12	120	103	90	80	72	65	60	
27	16	160	137	120	107	96	87	80	
30	20	200	171	150	133	120	109	100	
33	25	250	214	188	167	150	136	125	
36	29	289	249	218	193	174	158	145	
42	39	390	334	293	260	234	213	195	
48	50	500	429	375	333	300	273	250	
54	61	610	523	458	407	366	333	305	
60	74	740	634	555	493	444	404	370	
66	90	900	771	675	600	540	491	450	

NPK Fine 23 - 23 - 0

working width **39.4** FEET

Adjuster setting	Quantity spread lb/min	Tractor Speed mph						
		3,72	4,34	5	5,6	6	7	7,5
		lb/acre						
24	26	89	77	67	60	53	49	45
27	35	119	102	89	79	71	65	60
30	44	149	127	111	99	89	81	74
33	55	185	160	139	124	111	102	93
36	64	216	185	161	144	129	118	108
42	86	290	249	218	193	174	158	145
48	110	372	318	279	248	223	202	185
54	134	453	389	340	302	272	247	226
60	163	550	472	413	366	330	300	275
66	198	669	573	502	446	401	365	334

NPK Fino 23 - 23 - 0

anchura de trabajo **12** METROS

Posición del regulador	Cantidad esparcida kg/min	Velocidad del Tractor km/h						
		6	7	8	9	10	11	12
		kg por hectárea						
24	12	100	86	75	67	60	55	50
27	16	133	114	100	89	80	73	67
30	20	167	143	125	111	100	91	83
33	25	208	179	156	139	125	114	104
36	29	242	207	181	161	145	132	121
42	39	325	279	244	217	195	177	163
48	50	417	357	313	278	250	227	208
54	61	508	436	381	339	305	277	254
60	74	617	529	463	411	370	336	308
66	90	750	643	563	500	450	409	375

NPK Fine 23 - 23 - 0

working width **46** FEET

Adjuster setting	Quantity spread lb/min	Tractor Speed mph						
		3,72	4,34	5	5,6	6	7	7,5
		lb/acre						
24	26	77	65	57	51	45	42	38
27	35	102	87	77	67	62	55	51
30	44	127	109	95	85	77	70	63
33	55	160	136	119	107	95	86	79
36	64	184	159	138	123	111	101	93
42	86	249	213	186	166	149	136	124
48	110	318	273	239	212	191	174	160
54	134	389	333	292	259	233	212	194
60	163	472	404	353	314	283	257	235
66	198	573	491	430	382	344	313	286

NPK Fino 23 - 23 - 0

anchura de trabajo **14** METROS

Posición del regulador	Cantidad esparcida kg/min	Velocidad del Tractor km/h						
		6	7	8	9	10	11	12
		kg por hectárea						
24	12	86	73	64	57	51	47	43
27	16	114	98	86	76	69	62	57
30	20	143	122	107	95	86	78	71
33	25	179	153	134	119	107	97	89
36	29	207	178	155	138	124	113	104
42	39	279	239	209	186	167	152	139
48	50	357	306	268	238	214	195	179
54	61	436	373	327	290	261	238	218
60	74	529	453	396	352	317	288	264
66	90	643	551	482	429	386	351	321

Superphosphate 19%

working width **19.7** FEET

Adjuster setting	Quantity spread lb/min	Tractor Speed mph						
		3,72	4,34	5	5,6	6	7	7,5
		lb/acre						
21	33	223	191	168	149	134	121	111
24	46	312	267	234	208	187	170	156
27	57	386	331	290	258	232	210	193
30	70	475	407	357	318	285	259	238
33	83	564	484	424	376	339	308	283
36	101	684	586	513	456	410	373	341
42	139	936	802	703	624	562	511	468
48	180	1219	1044	914	812	731	664	609
54	233	1575	1350	1181	1050	945	860	787
60	293	1977	1694	1483	1318	1186	1078	988

Superfosfato 19%

anchura de trabajo **6** METROS

Posición del regulador	Cantidad esparcida kg/min	Velocidad del Tractor km/h						
		6	7	8	9	10	11	12
		kg por hectárea						
21	15	250	214	188	167	150	136	125
24	21	350	300	263	233	210	191	175
27	26	433	371	325	289	260	236	217
30	32	533	457	400	356	320	291	267
33	38	633	543	475	422	380	345	317
36	46	767	657	575	511	460	418	383
42	63	1050	900	788	700	630	573	525
48	82	1367	1171	1025	911	820	745	683
54	106	1767	1514	1325	1178	1060	964	883
60	133	2217	1900	1663	1478	1330	1209	1108

Superphosphate 19%

working width **29.5** FEET

Adjuster setting	Quantity spread lb/min	Tractor Speed mph						
		3,72	4,34	5	5,6	6	7	7,5
		lb/acre						
21	33	149	128	111	99	89	81	74
24	46	208	178	156	139	125	113	104
27	57	258	221	193	173	154	141	128
30	70	317	272	238	211	190	173	159
33	83	376	323	283	251	226	205	188
36	101	456	391	341	304	274	249	228
42	139	624	535	468	416	374	341	312
48	180	812	696	609	541	488	443	407
54	233	1050	901	787	700	630	572	525
60	293	1318	1130	988	878	791	719	659

Superfosfato 19%

anchura de trabajo **9** METROS

Posición del regulador	Cantidad esparcida kg/min	Velocidad del Tractor km/h						
		6	7	8	9	10	11	12
		kg por hectárea						
21	15	167	143	125	111	100	91	83
24	21	233	200	175	156	140	127	117
27	26	289	248	217	193	173	158	144
30	32	356	305	267	237	213	194	178
33	38	422	362	317	281	253	230	211
36	46	511	438	383	341	307	279	255
42	63	700	600	525	467	420	382	350
48	82	911	781	683	607	547	497	456
54	106	1178	1010	883	785	707	642	589
60	133	1478	1267	1108	985	887	806	739

Superphosphate 19%

working width **32.8** FEET

Adjuster setting	Quantity spread lb/min	Tractor Speed mph						
		3,72	4,34	5	5,6	6	7	7,5
		lb/acre						
21	33	134	115	101	89	80	73	67
24	46	187	160	141	125	111	103	94
27	57	232	199	174	154	139	127	116
30	70	285	244	214	190	171	156	143
33	83	339	291	254	226	203	185	169
36	101	410	351	308	274	246	224	205
42	139	562	481	422	374	337	307	281
48	180	731	627	548	488	439	399	366
54	233	945	810	709	630	567	515	473
60	293	1186	1016	890	791	711	646	593

Superfosfato 19%

anchura de trabajo **10** METROS

Posición del regulador	Cantidad esparcida kg/min	Velocidad del Tractor km/h						
		6	7	8	9	10	11	12
		kg por hectárea						
21	15	150	129	113	100	90	82	75
24	21	210	180	158	140	126	115	105
27	26	260	223	195	173	156	142	130
30	32	320	274	240	213	192	175	160
33	38	380	326	285	253	228	207	190
36	46	460	394	345	307	276	251	230
42	63	630	540	473	420	378	344	315
48	82	820	703	615	547	492	447	410
54	106	1060	909	795	707	636	578	530
60	133	1330	1140	998	887	798	725	665

Superphosphate 19%

working width **39.4** FEET

Adjuster setting	Quantity spread lb/min	Tractor Speed mph						
		3,72	4,34	5	5,6	6	7	7,5
		lb/acre						
21	33	111	95	84	74	67	61	56
24	46	156	133	117	104	94	85	78
27	57	193	166	145	128	116	105	96
30	70	238	204	178	159	143	129	119
33	83	283	242	212	188	169	154	141
36	101	341	293	257	228	205	186	171
42	139	468	401	351	312	281	255	234
48	180	609	522	457	407	366	333	305
54	233	787	675	591	525	473	430	394
60	293	988	847	741	659	593	539	494

Superfosfato 19%

anchura de trabajo **12** METROS

Posición del regulador	Cantidad esparcida kg/min	Velocidad del Tractor km/h						
		6	7	8	9	10	11	12
		kg por hectárea						
21	15	125	107	94	83	75	68	63
24	21	175	150	131	117	105	95	88
27	26	217	186	163	144	130	118	108
30	32	267	229	200	178	160	145	133
33	38	317	271	238	211	190	173	158
36	46	383	329	288	256	230	209	192
42	63	525	450	394	350	315	286	263
48	82	683	586	513	456	410	373	342
54	106	883	757	663	589	530	482	442
60	133	1108	950	831	739	665	605	554

Superphosphate 19%

working width **46** FEET

Adjuster setting	Quantity spread lb/min	Tractor Speed mph						
		3,72	4,34	5	5,6	6	7	7,5
		lb/acre						
21	33	95	82	71	64	57	52	48
24	46	134	115	101	89	80	73	67
27	57	166	142	124	110	99	90	83
30	70	204	175	152	136	122	111	102
33	83	242	208	182	161	145	132	121
36	101	293	251	219	196	174	160	146
42	139	401	344	301	267	241	218	201
48	180	522	448	391	348	313	284	261
54	233	675	579	506	450	405	368	338
60	293	847	726	636	564	508	462	424

K.C.L. 60

working width **19.7** FEET

Adjuster setting	Quantity spread lb/min	Tractor Speed mph						
		3,72	4,34	5	5,6	6	7	7,5
		lb/acre						
21	18	119	102	89	79	71	65	60
24	24	163	140	123	109	98	89	82
27	33	223	191	168	149	134	121	111
30	42	283	242	212	188	169	154	141
33	48	327	280	245	218	196	178	163
36	55	372	318	279	248	223	202	185
42	79	535	458	401	357	321	292	267
48	101	684	586	513	456	410	373	341
54	125	847	726	636	564	508	462	423
60	158	1070	917	802	713	642	584	535

K.C.L. 60

working width **29.5** FEET

Adjuster setting	Quantity spread lb/min	Tractor Speed mph						
		3,72	4,34	5	5,6	6	7	7,5
		lb/acre						
21	18	79	68	60	53	47	43	39
24	24	109	94	82	72	65	60	54
27	33	149	128	111	99	89	81	74
30	42	188	161	141	126	113	103	95
33	48	218	187	163	146	131	119	109
36	55	248	212	186	165	149	136	124
42	79	357	306	268	238	214	194	178
48	101	456	391	342	305	274	249	228
54	125	565	484	424	376	339	308	283
60	158	714	612	535	475	428	389	357

Superfosfato 19%

anchura de trabajo **14** METROS

Posición del regulador	Cantidad esparcida kg/min	Velocidad del Tractor km/h						
		6	7	8	9	10	11	12
		kg por hectárea						
21	15	107	92	80	71	64	58	54
24	21	150	129	113	100	90	82	75
27	26	186	159	139	124	111	101	93
30	32	229	196	171	152	137	125	114
33	38	271	233	204	181	163	148	136
36	46	329	282	246	219	197	179	164
42	63	450	386	338	300	270	245	225
48	82	586	502	439	390	351	319	293
54	106	757	649	568	505	454	413	379
60	133	950	814	713	633	570	518	475

K.C.L. 60

anchura de trabajo **6** METROS

Posición del regulador	Cantidad esparcida kg/min	Velocidad del Tractor km/h						
		6	7	8	9	10	11	12
		kg por hectárea						
21	8	133	114	100	89	80	73	67
24	11	183	157	138	122	110	100	92
27	15	250	214	188	167	150	136	125
30	19	317	271	238	211	190	173	158
33	22	367	314	275	244	220	200	183
36	25	417	357	313	278	250	227	208
42	36	600	514	450	400	360	327	300
48	46	767	657	575	511	460	418	383
54	57	950	814	713	633	570	518	475
60	72	1200	1029	900	800	720	655	600

K.C.L. 60

anchura de trabajo **9** METROS

Posición del regulador	Cantidad esparcida kg/min	Velocidad del Tractor km/h						
		6	7	8	9	10	11	12
		kg por hectárea						
21	8	89	76	67	59	53	48	44
24	11	122	105	92	81	73	67	61
27	15	167	143	125	111	100	91	83
30	19	211	181	158	141	127	115	106
33	22	244	210	183	163	147	133	122
36	25	278	238	208	185	167	152	139
42	36	400	343	300	267	240	218	200
48	46	511	438	383	341	307	279	256
54	57	633	543	475	422	380	345	317
60	72	800	686	600	533	480	436	400

K.C.L. 60

working width **32.8** FEET

Adjuster setting	Quantity spread lb/min	Tractor Speed mph						
		3,72	4,34	5	5,6	6	7	7,5
		lb/acre						
24	24	98	84	74	65	59	54	49
27	33	134	115	101	89	80	73	67
30	42	169	145	128	113	102	93	85
33	48	196	169	147	131	118	107	98
36	55	223	191	168	149	134	121	111
42	79	321	276	241	214	193	175	161
48	101	410	351	308	274	246	224	205
54	125	508	436	382	339	305	277	254
60	158	642	550	482	430	385	351	321
66	198	803	688	602	535	482	438	401

K.C.L. 60

anchura de trabajo **10** METROS

Posición del regulador	Cantidad esparcida kg/min	Velocidad del Tractor km/h						
		6	7	8	9	10	11	12
		kg por hectárea						
24	11	110	94	83	73	66	60	55
27	15	150	129	113	100	90	82	75
30	19	190	163	143	127	114	104	95
33	22	220	189	165	147	132	120	110
36	25	250	214	188	167	150	136	125
42	36	360	309	270	240	216	196	180
48	46	460	394	345	307	276	251	230
54	57	570	489	428	380	342	311	285
60	72	720	617	540	480	432	393	360
66	90	900	771	675	600	540	491	450

K.C.L. 60

working width **39.4** FEET

Adjuster setting	Quantity spread lb/min	Tractor Speed mph						
		3,72	4,34	5	5,6	6	7	7,5
		lb/acre						
24	24	82	70	62	54	49	45	41
27	33	111	95	84	74	67	61	56
30	42	141	121	106	95	84	77	70
33	48	163	140	123	109	98	89	82
36	55	185	160	139	124	111	102	93
42	79	267	229	200	179	160	146	134
48	101	341	293	257	228	205	186	171
54	125	424	363	317	283	254	231	212
60	158	535	458	401	357	321	292	267
66	198	669	573	502	446	401	365	334

K.C.L. 60

anchura de trabajo **12** METROS

Posición del regulador	Cantidad esparcida kg/min	Velocidad del Tractor km/h						
		6	7	8	9	10	11	12
		kg por hectárea						
24	11	92	79	69	61	55	50	46
27	15	125	107	94	83	75	68	63
30	19	158	136	119	106	95	86	79
33	22	183	157	138	122	110	100	92
36	25	208	179	156	139	125	114	104
42	36	300	257	225	200	180	164	150
48	46	383	329	288	256	230	209	192
54	57	475	407	356	317	285	259	238
60	72	600	514	450	400	360	327	300
66	90	750	643	563	500	450	409	375

Agricultural Lime with stirring device

working width **19.7** FEET

Adjuster setting	Quantity spread lb/min	Tractor Speed mph						
		3,72	4,34	5	5,6	6	7	7,5
		lb/acre						
34	46	312	267	234	208	187	170	156
39	68	461	395	346	307	276	251	230
46	94	639	547	480	426	383	349	319
53	158	1070	917	802	713	642	584	535
62	262	1768	1516	1327	1179	1061	965	884

Cal Agrícola con agitador

anchura de trabajo **6** METROS

Posición del regulador	Cantidad esparcida kg/min	Velocidad del Tractor km/h						
		6	7	8	9	10	11	12
		kg por hectárea						
34	21	350	300	263	233	210	191	175
39	31	517	443	388	344	310	282	258
46	43	717	614	538	478	430	391	358
53	72	1200	1029	900	800	720	655	600
62	119	1983	1700	1488	1322	1190	1082	992

Rye Grass Seed with stirring device

working width **19.7** FEET

Adjuster setting	Quantity spread lb/min	Tractor Speed mph						
		3,72	4,34	5	5,6	6	7	7,5
		lb/acre						
18	3	24	21	18	16	14	13	12
19	4	27	23	21	18	16	14	13
20	4	29	26	22	20	18	16	15
22	5	37	32	28	25	22	20	19

Semilla de Rye Grass con agitador

anchura de trabajo **6** METROS

Posición del regulador	Cantidad esparcida kg/min	Velocidad del Tractor km/h						
		6	7	8	9	10	11	12
		kg por hectárea						
18	1.6	27	23	20	18	16	15	13
19	1.8	30	26	23	20	18	16	16
20	2.0	33	29	25	22	20	18	17
22	2.5	42	36	31	28	25	23	21

Wheat Seed

working width **32.8** FEET

Adjuster setting	Quantity spread lb/min	Tractor Speed mph						
		3,72	4,34	5	5,6	6	7	7,5
		lb/acre						
27	35	129	111	97	86	78	70	65
30	48	178	152	134	119	107	97	89
36	62	227	194	170	152	136	124	113
39	70	259	222	194	173	156	142	129

Semilla de Trigo

anchura de trabajo **10** METROS

Posición del regulador	Cantidad esparcida kg/min	Velocidad del Tractor km/h						
		6	7	8	9	10	11	12
		kg por hectárea						
27	16	145	125	109	97	87	79	73
30	22	200	171	150	133	120	109	100
36	28	254	218	191	170	153	139	127
39	32	291	249	218	194	175	159	145

Working width refers to the distance from center to center of each run. This will usually be half the total spreading width to allow for a correct overlap and even spread pattern (See page 10).

Note: The productions mentioned above can present variations according to the product humidity grade, specific height and work conditions. Specifications and design are subject to change without notice.

La anchura de trabajo se refiere a la distancia de centro a centro de cada pasada. Eso normalmente será la mitad del total de la anchura del esparcimiento permitiendo sobreponerse de forma correcta y obtener el patrón regular de esparcimiento (consulte la página 20).

Nota: Las producciones citadas en las tablas en este manual son medias obtenidas en condiciones de prueba, variando de acuerdo con el grado de humedad del producto, peso específico y condiciones de trabajo. Vicon Máquinas Agrícolas Ltda se reserva el derecho de alterar sus productos sin previo aviso.

SPREADER UNIT
UNIDAD DE LA ABONADORA

SERIES 22400
SERIE 22400

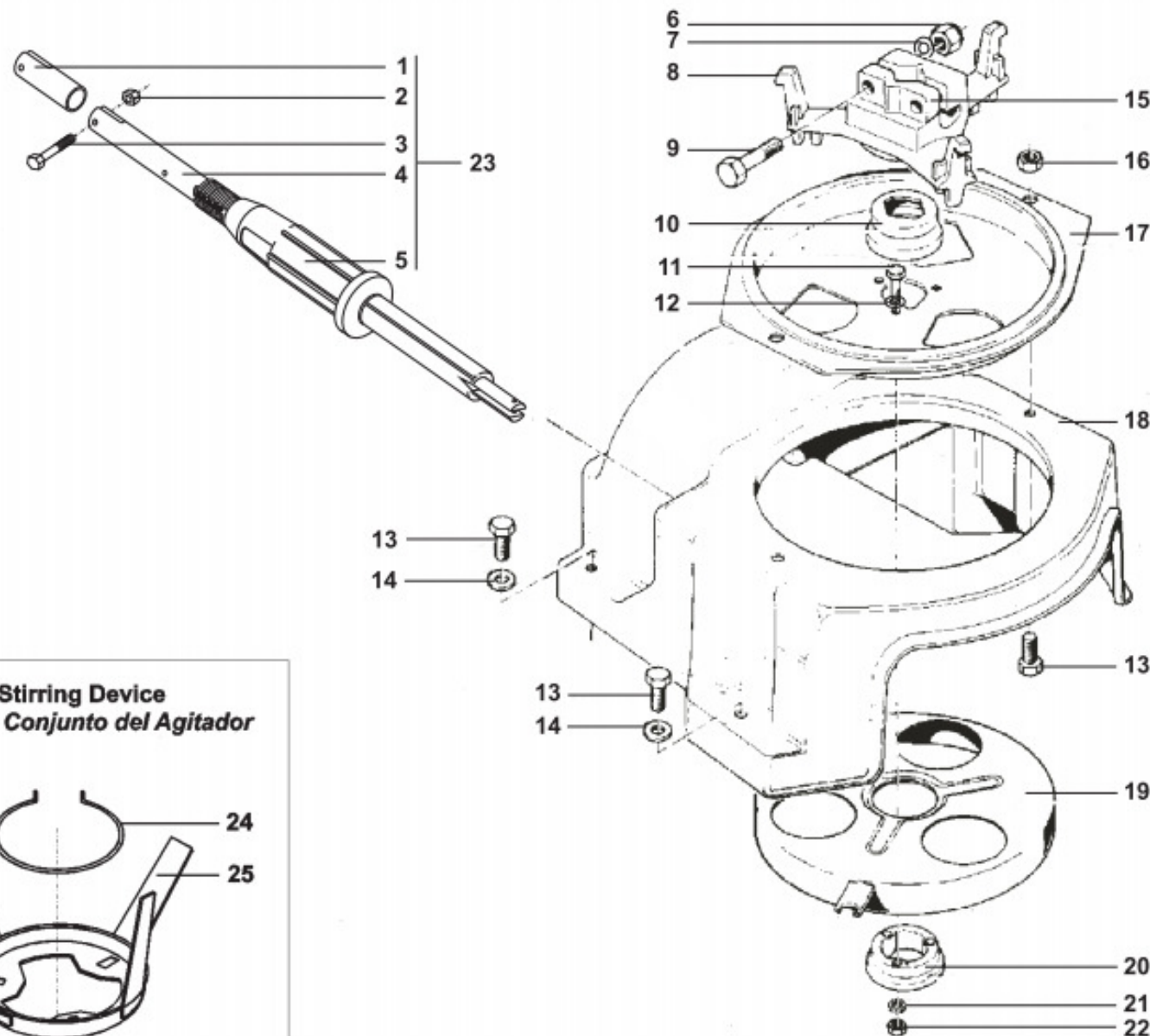

option: **Stirring Device**
opción: **Conjunto del Agitador**

Nº	Reference	Quantity per machine
Nº	Referencia	Cantidad por máquina
1	52429	1
2	305.75.600	2
3	302.71.625	1
4	70437	1
5	70524	1
6	305.61.300	2
7	314.53.301	2
8	21406	1
9	302.70.360	2
10	70589	1
11	302.70.525	3
12	314.53.501	3
13	302.98.120	6
14	314.97.100	4
15	21142	1
16	305.96.100	2
17	70542	1
18	70927	1
19	15097	1
20	20041	1
21	314.53.500	3
22	305.61.500	3
23	ug000804	1

Stirring Device Assy Conjunto del Agitador		
24	36180	1
25	15445	1

SPREADER UNIT

UNIDAD DE LA ABONADORA

SERIES 22400

SERIE 22400

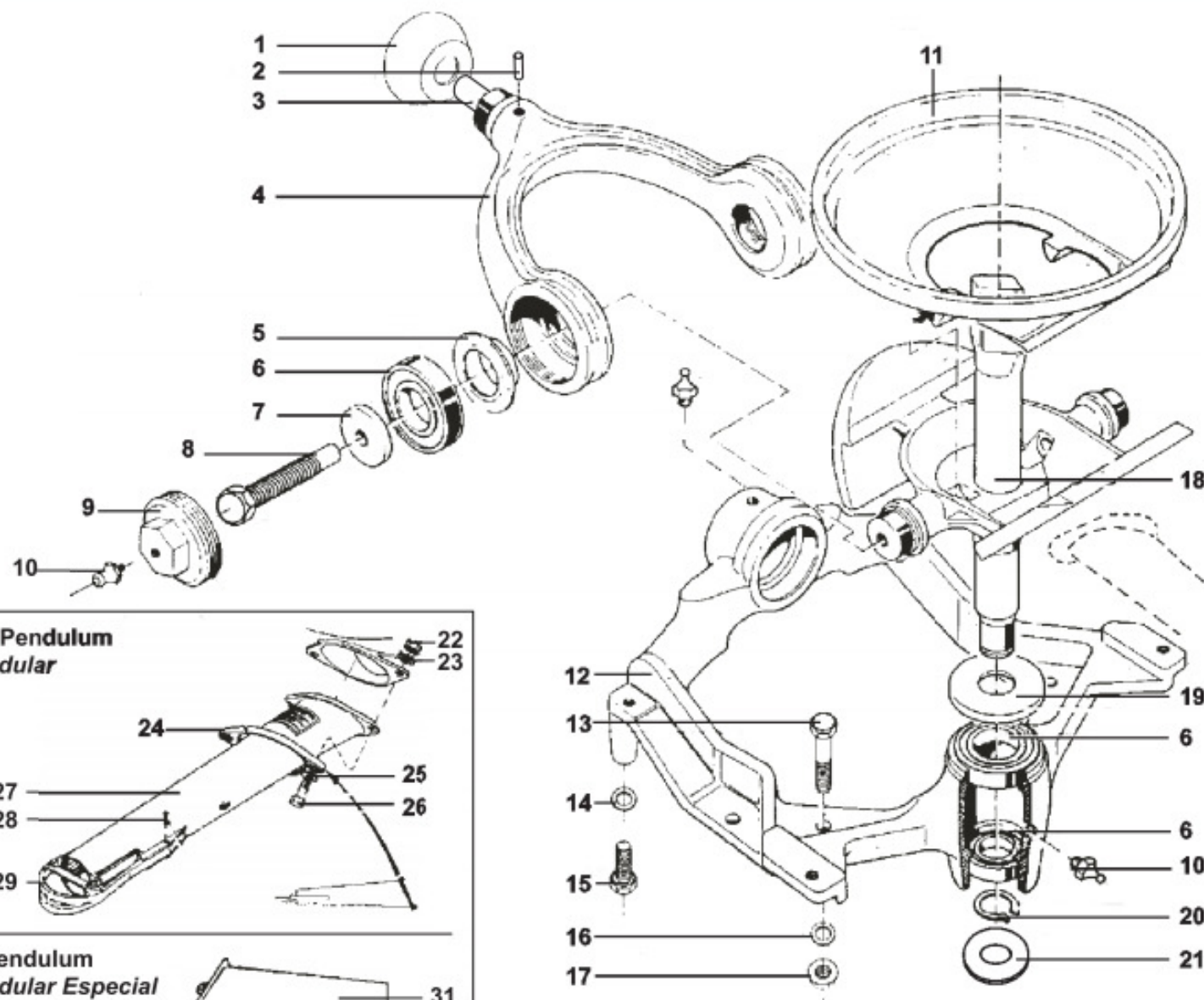

Standard Pendulum
Tubo Pendular

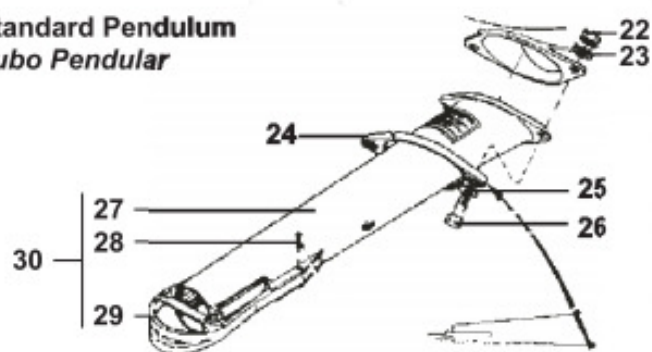

Special Pendulum
Tubo Pendular Especial



Nº	Reference	Quantity per machine
Nº	Referencia	Cantidad por máquina
1	70629	1
2	308.03.540	1
3	43839	1
4	96439	1
5	71178	2
6	401.01.206	4
7	40851	2
8	302.68.290	2
9	70548	2
10	417.61.200	4
11	70632	1
12	21956	1
13	302.71.245	4
14	314.97.100	2
15	302.98.120	2
16	314.53.300	4
17	305.83.200	4
18	96422	1
19	70633	1
20	310.01.300	1
21	70188	1

Standard Pendulum
Tubo Pendular

22	305.53.800	2
23	314.53.300	2
24	83262	1
25	314.61.250	2
26	302.90.855	2
27	mp118202	1
28	312.04.320	2
29	70413	1
30	07665	1

Special Pendulum
Tubo Pendular Especial

31	70445	1
----	-------	---

SPREADER UNIT
UNIDAD DE LA ABONADORA

SERIES 22400
SERIE 22400

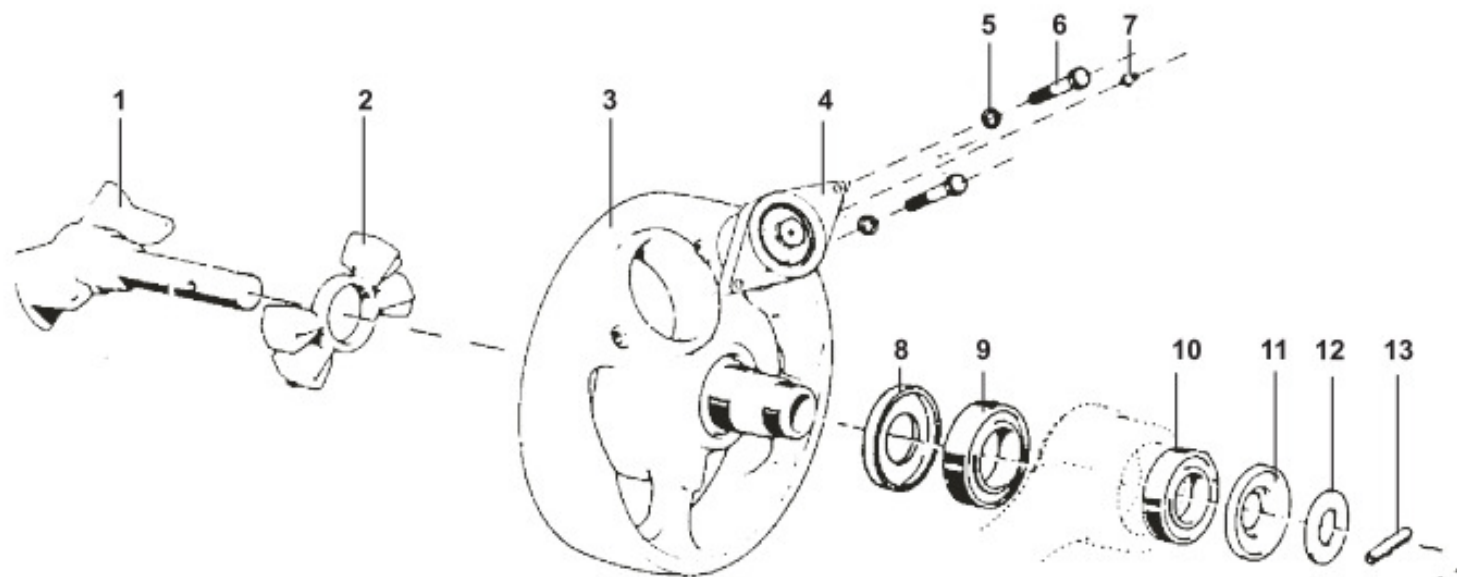

up000805 - option (N° 1)
up000805 - opción (N° 1)

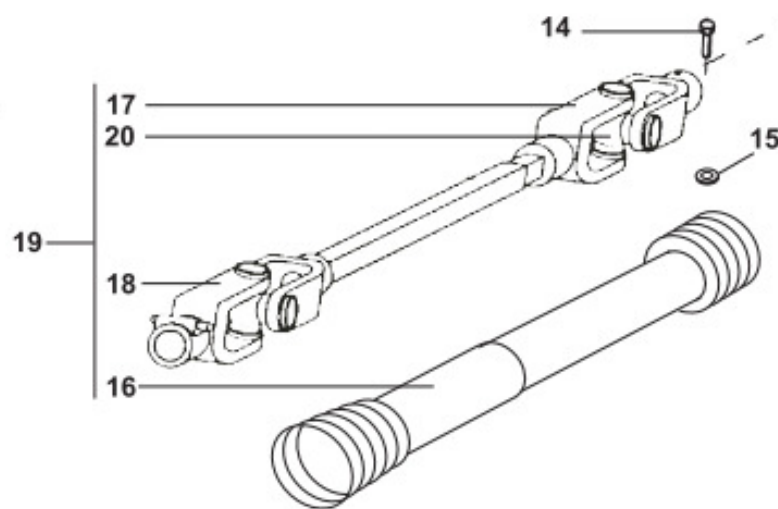
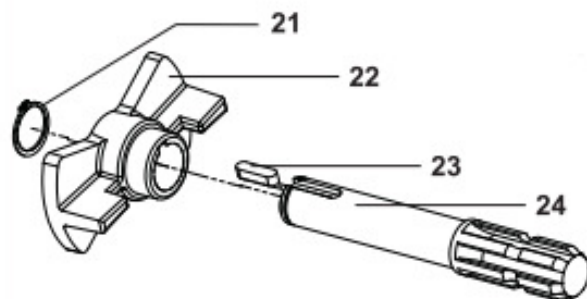

N°	Reference	Quantity per machine
N°	Referencia	Cantidad por máquina
1	95963	1
2	70527	1
3	up400810	1
4	95629	1
5	314.53.200	2
6	302.70.840	2
7	417.61.200	1
8	71119	1
9	401.02.450	1
10	401.02.209	1
11	71118	1
12	69902	1
13	308.03.170	1
14	308.03.155	1
15	305.96.100	2

PTO Shaft
Cardán

16	95560	1
17	95557	1
18	95556	1
19	95558	1
20	310-cz-101	2

option (N° 1)
opción (N° 1)

21	mp132100	1
22	up400808	1
23	mp131765	1
24	up200807	1

CHASSIS AND HOPPER: PS 203, PS 303
CHASIS Y TOLVA: PS 203, PS 303

SERIES 22400
SERIE 22400

PS 203
 PS 203

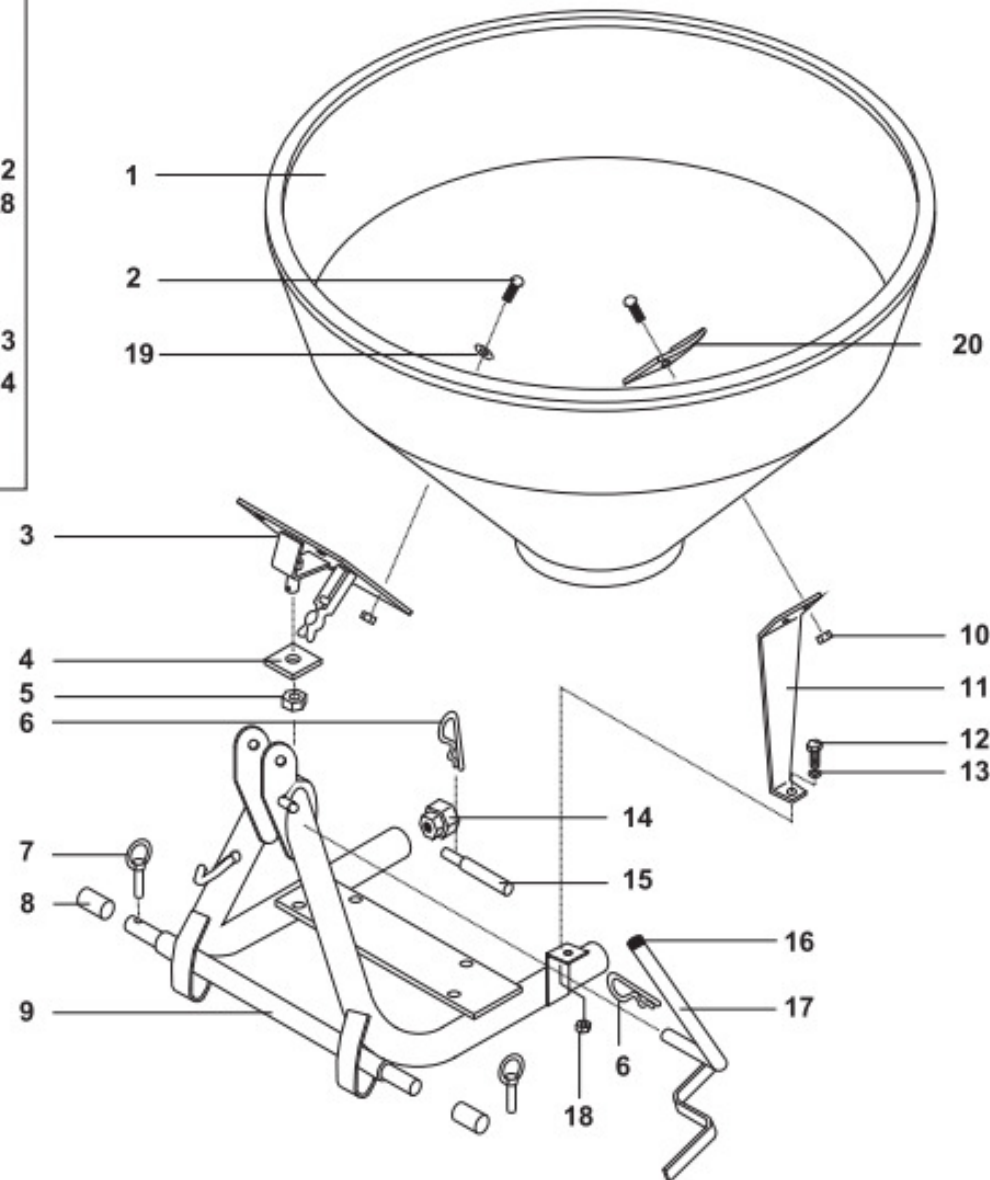
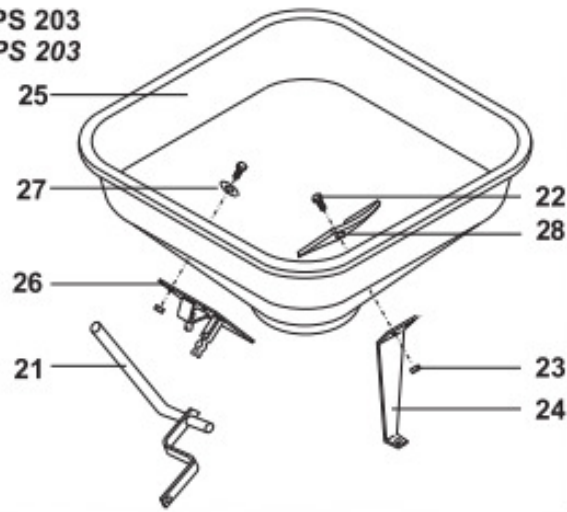

Nº	Reference	Quantity per machine
Nº	Referencia	Cantidad por máquina
1	70308	1
2	80952	10
3	15253	1
4	70330	1
5	mp131105	1
6	91569	2
7	94887	2
8	70301	2
9	80202	1
10	305.85.100	10
11	15254	2
12	302.98.120	2
13	314.97.100	2
14	70300	2
15	43838	1
16	83138	1
17	15242	1
18	305.96.100	2
19	ps211211	4
20	ps611000	2

PS 203
 PS 203

21	ps015006	1
22	80952	9
23	305.85.100	9
24	ps215010	2
25	ps111209	1
26	ps211208	1
27	ps211211	3
28	ps611000	2

CHASSIS AND HOPPER: PS 403S, PS 503S, PS 603S
CHASIS Y TOLVA : PS 403S, PS 503S, PS 603S

SERIES 22400
SERIE 22400

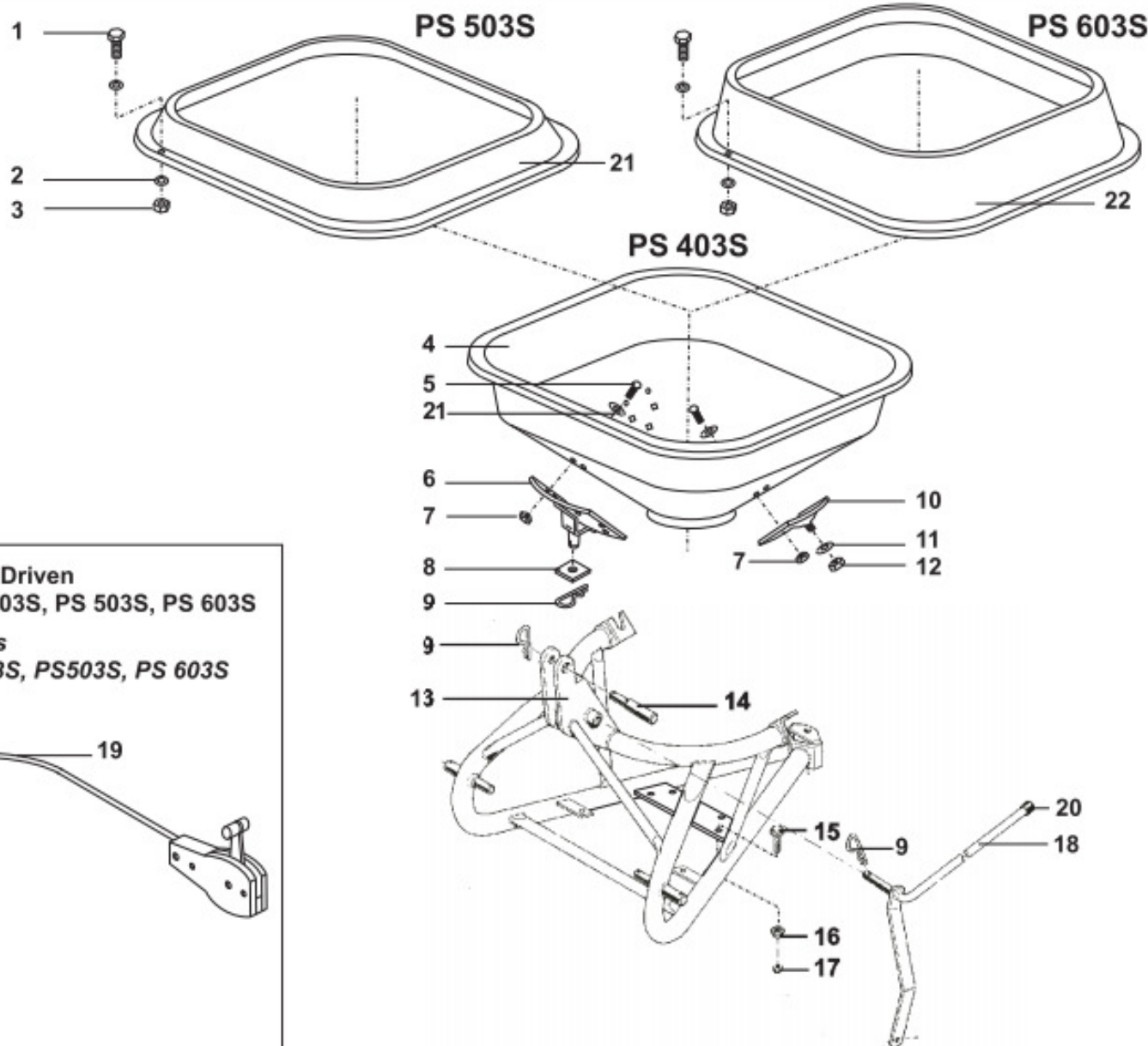

Complete Cable - Driven
Commands: PS 403S, PS 503S, PS 603S
Mando por Cables
Completa: PS 403S, PS503S, PS 603S

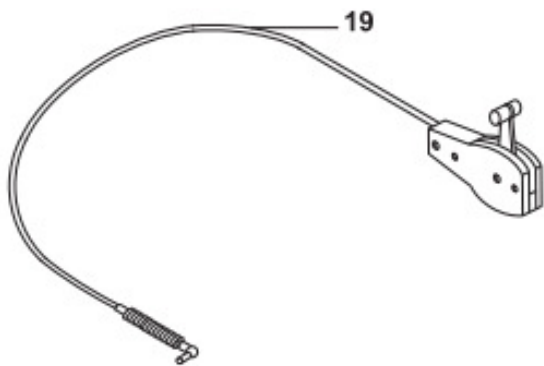

Nº	Reference	Quantity per machine
Nº	Referencia	Cantidad por máquina
1	302.71.825	6
2	314.61.800	12
3	305.61.800	6
4	70304	1
5	80952	14
6	15250	1
7	305.85.100	14
8	70330	1
9	91569	3
10	15252	2
11	314.61.250	2
12	305.61.200	2
13	80201	1
14	43838	1
15	302.71.245	4
16	314.53.300	4
17	305.83.200	4
18	15241	1
19	ps014500	1
20	83138	1
21	ps211211	14

Options to increase capacity of hopper
Opción para aumentar la capacidad de la tolva

21	70317	1
22	70318	1

CABLE: PS 603S, PS 753/Trailer
CABLES: PS 603S, PS 753/Carreta

SERIES 22400
SERIE 22400

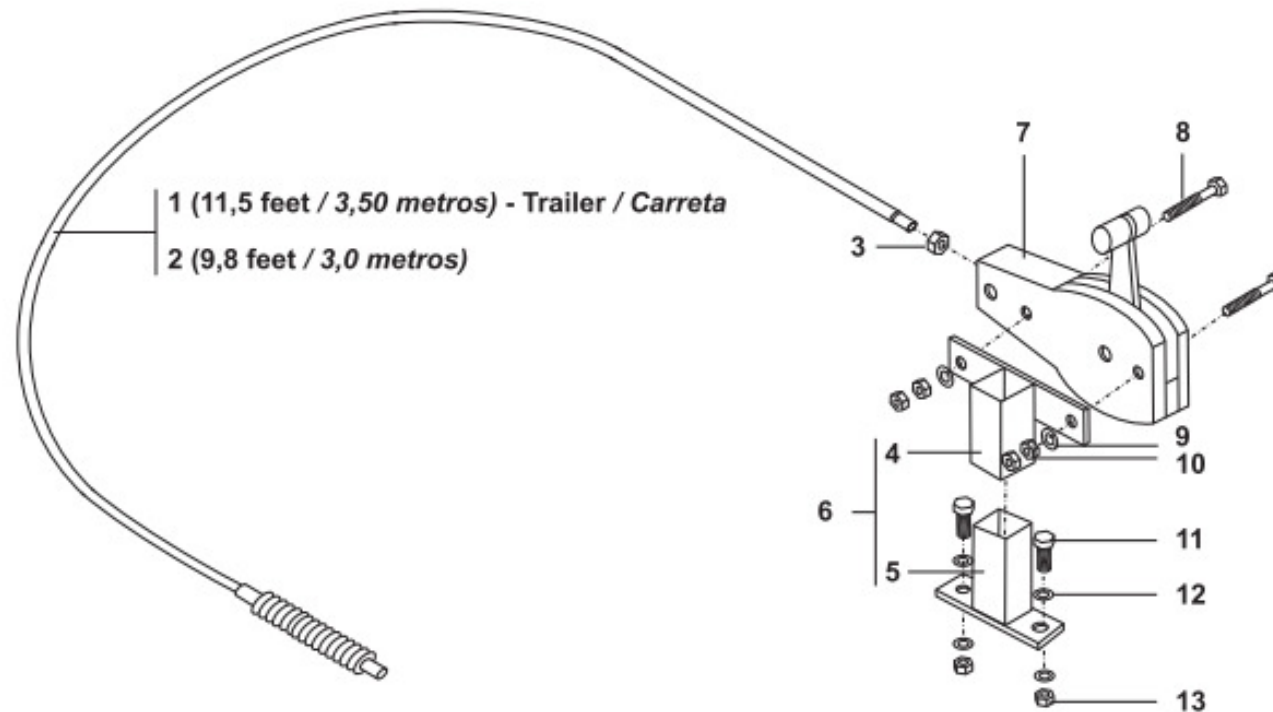

Nº	Reference	Quantity per machine
Nº	Referencia	Cantidad por máquina
1	mp041502	1
2	mp041501	1
3	mp131303	2
4	ug214507	1
5	ug214509	1
6	ug014505	1
7	ps014501	1
8	mp131042	2
9	mp131508	2
10	mp131107	4
11	mp131006	2
12	mp131502	4
13	mp131103	2

PS 603S PS 603S		
14	88026	1
15	20203	1
16	302.71.825	2
17	305.61.800	2
18	314.61.800	2
19	20206	1
20	20200	1

PS 603S
PS 603S

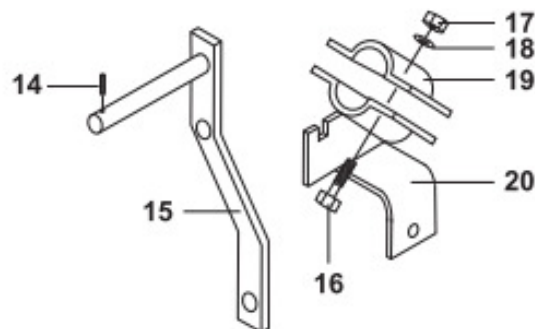

PS 753 / Trailer
PS 753 / Carreta

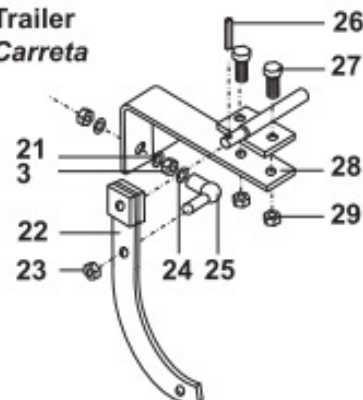

PS 753 / Trailer PS 753 / Carreta		
21	mp131509	2
22	ps214515	1
23	mp131301	1
24	mp131511	2
25	ps714501	1
26	mp132013	1
27	mp131421	2
28	ps214518	1
29	mp131702	2

TRAILER: PS 1353T, PS 1553T
 CARRETA: PS 1353T, PS 1553T

SERIES 22400
 SERIE 22400

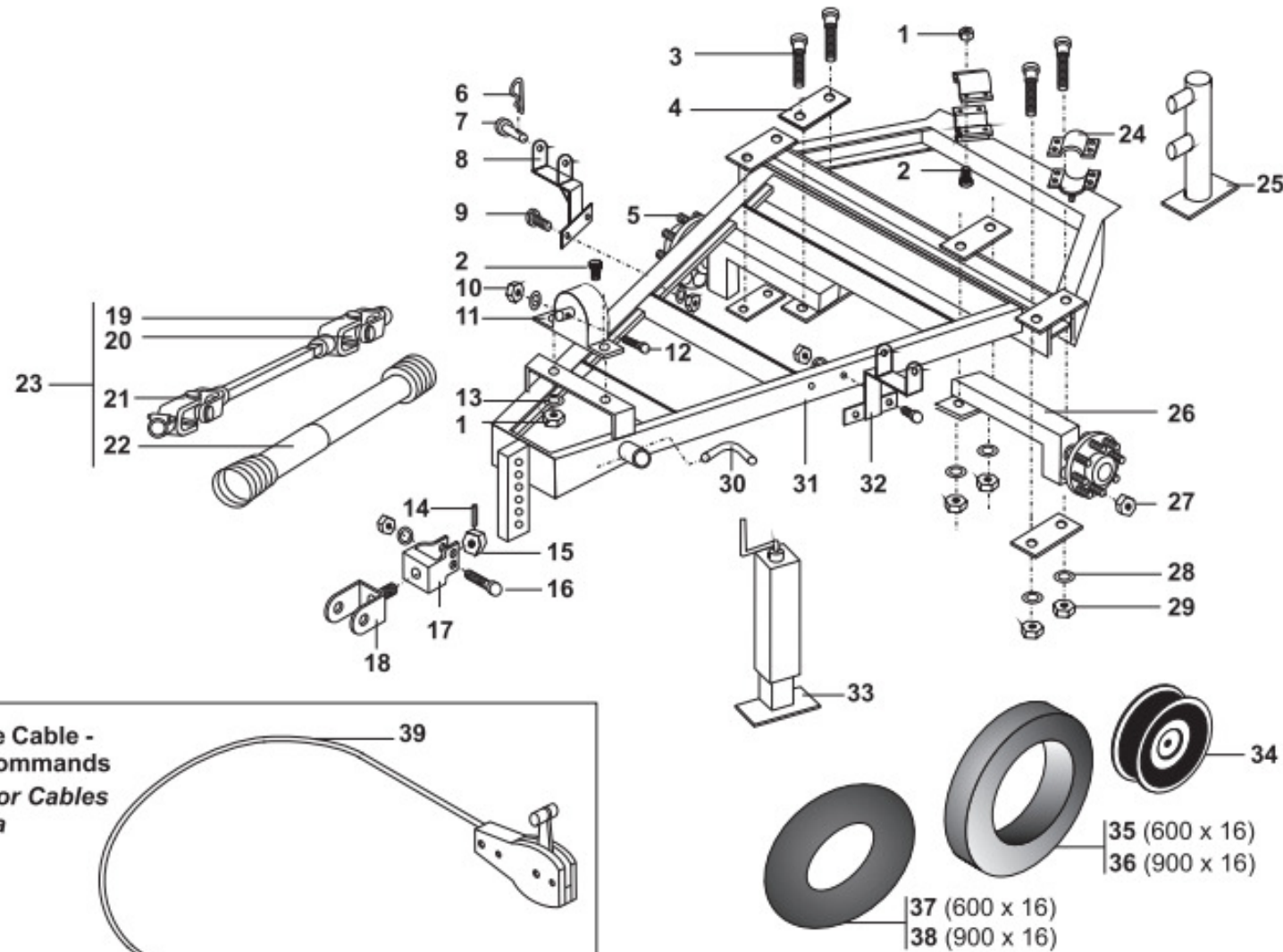

Complete Cable -
 Driven Commands
 Mando por Cables
 Completa

Nº	Reference	Quantity
Nº	Referencia	per machine Cantidad por máquina
1	305.83.200	10
2	302.71.245	10
3	302.70.145	8
4	80209	4
5	60014	2
6	91569	4
7	80214	2
8	80207	1
9	302.70.143	4
10	305.96.100	4
11	80215	1
12	308.03.155	2
13	314.61.250	2
14	308.03.550	1
15	305.96.192	1
16	302.70.144	2
17	80210	1
18	80211	1
19	2303-144	1
20	310-cz-101	2
21	2303-143	1
22	95561	1
23	2303-145	1
24	80213	2
25	80212	1
26	60013	2
27	305.96.191	12
28	314.53.195	14
29	305.96.190	14
30	cr215041	2
31	80205	1
32	80206	1
33	80208	1
34	60015	2
35	60016	2
36	60017	2
37	60018	2
38	60019	2
39	ps014502	1

vicon máquinas agrícolas Ltda.

Rua Dr. Ladislau Retti, 1399
Parque Alexandre - CEP 06714-150
Cotia - SP - Brasil
Tel.: 11 4617-8040 Fax: 11 4617-8041

e-mail: vicon@vicon.com.br
site: www.vicon.com.br

